

# Crestron Isys<sup>®</sup> **TPS-12B/W,** **TPS-15B/W & TPS-17B/W**

Tilt Touchpanels

---

## Operations Guide



This document was prepared and written by the Technical Documentation department at:



Crestron Electronics, Inc.

15 Volvo Drive

Rockleigh, NJ 07647

1-888-CRESTRON

# Contents

## Crestron Isys® Tilt Touchpanels: TPS-12B/W, TPS-15B/W & TPS-17B/W 1

|   |    |
|---|----|
| Introduction .....                                      | 1  |
| Features and Functions .....                            | 1  |
| Internal Block Diagram .....                            | 4  |
| Specifications .....                                    | 5  |
| Physical Description .....                              | 8  |
| Industry Compliance .....                               | 16 |
| Setup .....   | 17 |
| Network Wiring .....                                    | 17 |
| Ethernet .....  | 17 |
| CAT5 Wiring .....                                       | 17 |
| QuickMedia Wiring .....                                 | 18 |
| Identity Code .....                                     | 19 |
| Configuring the Touchpanel .....                        | 20 |
| Hardware Hookup .....                                   | 35 |
| Tilt Angle Tension Adjustment .....                     | 38 |
| Recommended Cleaning .....                              | 38 |
| Programming Software .....                              | 39 |
| Earliest Version Software Requirements for the PC ..... | 39 |
| Programming with Crestron SystemBuilder .....           | 39 |
| Programming with SIMPL Windows .....                    | 39 |
| Programming with VisionTools Pro-e .....                | 43 |
| Example Program .....                                   | 46 |
| Uploading and Upgrading .....                           | 47 |
| Establishing Communication .....                        | 47 |
| Programs, Projects and Firmware .....                   | 48 |
| Program Checks .....                                    | 49 |
| Problem Solving .....                                   | 50 |
| Troubleshooting .....                                   | 50 |
| Check Network Wiring .....                              | 51 |
| Reference Documents .....                               | 52 |
| Further Inquiries .....                                 | 52 |
| Future Updates .....                                    | 53 |
| Software License Agreement .....                        | 54 |
| Return and Warranty Policies .....                      | 56 |
| Merchandise Returns / Repair Service .....              | 56 |
| CRESTRON Limited Warranty .....                         | 56 |



# Crestron Isys® Tilt Touchpanels: TPS-12B/W, TPS-15B/W & TPS-17B/W

---

## Introduction

The features and specifications for all three touchpanels are identical, except for those relating to the screen. The touchpanels are available in black or white, designated by the B or W in the model name.

## Features and Functions

- 12, 15 and 17 inch (widescreen) active matrix touchscreen displays
- Screen resolutions: TPS-12B/W 800 x 600, TPS-15B/W 1024 x 768, TPS-17B/W 1280 x 768
- 16.7 million colors, 24-bit Isys® graphics with 8-bit alpha channel and Synapse™ image rendering algorithm
- Full-motion video with gamma correction and motion adaptive deinterlacing; full screen video capability
- Built-in time base correction for stable video and graphics
- Supports composite, S-video and component inputs in both NTSC and PAL formats
- Supports QuickMedia™ transport technology, which affords expanded AV connectivity through a streamlined wiring solution
- Supports Crestron Home® CAT5 balanced A/V connectivity
- Up to 4,000 digital and analog signals; up to 999 serial signals
- Built-in amplified speaker system and microphone
- Stores and plays back WAV sound files
- Stereo headphone jack
- Balanced stereo audio input and output
- 10BaseT/100BaseTX high-speed Ethernet, 802.3U compliant, full duplex, auto switching
- High speed Cresnet® communications

*(Continued on following page)*

*Features and Functions (Continued)*

- Backlit “softkey” buttons
- 128 MB of DDR RAM, 32 MB of internal flash (expandable to 160 MB)
- Includes a TPMC-CH-IMC to facilitate A/V connections
- Tiltcase housing with integral rear cover and cable strain relief
- Available in black with silver accent or white with gray accent

**Isys<sup>®</sup>**

Isys power and beauty are infused throughout Crestron’s entire touchpanel lineup. Under the hood, the TPS-12B/W, TPS-15B/W & TPS-17B/W offer vibrant 24-bit color depth to produce incredible 3D graphics, high-res images, translucence, dynamic text and graphics, full-motion animations, multimode objects and dramatic transition effects, all with astonishing speed.

**Synapse<sup>™</sup>**

Crestron’s exclusive Synapse Image Rendering Algorithm enables system programmers to produce amazing graphics – faster and easier. Advanced antialiasing delivers crisper, sharper objects and text. Enhanced 3D effects add new depth and style. And because Synapse is native to the touchpanel, memory requirements and upload time are substantially reduced.

**High Performance Video**

The TPS-12B/W, TPS-15B/W & TPS-17B/W can display full-motion video from an external AV source, either full screen or in a scalable window. Motion adaptive deinterlacing brings out the finest detail, minimizing visible scan lines and motion artifacts for a truly remarkable picture. Advanced gamma correction and built-in time base correction ensure accurate color reproduction and a jitter-free image. Two video inputs provide for connectivity to QuickMedia and PVID video distribution switches (such as the CNX-PVID8X3 or CNX-PVID8X4).

**High Quality Audio**

The high-powered amplified speaker system provides amplification for external AV sources and supports intercom functionality in combination with the integrated microphone. Customized WAV files can be loaded on the touchpanel to add dimension to the touchscreen graphics with personalized sounds, button feedback and voice prompts. The TPS-12B/W, TPS-15B/W & TPS-17B/W touchpanels are also equipped with balanced output for microphone audio that can be connected to a Crestron CNX-BIPAD8 or similar Crestron CAT5 audio receiver.

**Crestron Home<sup>®</sup> CAT5 AV**

Connecting audio and video sources to the TPS-12B/W, TPS-15B/W & TPS-17B/W 7L is facilitated using inexpensive CAT5 wire, enabling direct connection to Crestron’s popular CAT5 balanced audio and video distribution switchers. A single video input port accepts signals from composite, S-video and standard definition components sources over wiring distances of up to 750 feet. A bidirectional audio port receives stereo program audio and intercom signals and outputs audio from the internal microphone. To facilitate direct connection of conventional video and audio devices, an external interface module is included.

### **QuickMedia™**

The TPS-12B/W, TPS-15B/W & TPS-17B/W are also equipped with a single QuickMedia input port. Through QuickMedia (QM), the TPS-12B/W, TPS-15B/W & TPS-17B/W interface directly with Crestron's QM-based MediaManager products using a single CAT5e type cable. Over wiring distances of up to 300 feet, the QM input port accepts video signals from composite, S-video and standard definition component sources along with discrete audio signals from one stereo program source and up to two microphones. For more information on QM applications, refer to the latest revision of the Crestron MediaManager Applications Guide (Doc. 6244) which is available from the Crestron website (<http://www.crestron.com/manuals>).

---

**NOTE:** The TPS-12B/W, TPS-15B/W & TPS-17B/W do not support RGB.

---

### **High-Speed Connectivity**

Both Cresnet and high-speed Ethernet are standard on the TPS-12B/W, TPS-15B/W & TPS-17B/W, providing for easy network integration and seamless communications with Crestron control systems. In addition, a USB port is provided for future applications. The "RS-232 Port for Touch Output" operation transmits touch coordinates to external devices via RS-232 for "Touch-The-PC" and other functions.

### **Cresnet®**

Cresnet is the communications backbone for many Crestron touchpanels, keypads, lighting controls and other devices. The Cresnet bus is a simple, yet flexible 4-wire network that provides rock-solid bidirectional communication and power for up to 252 Cresnet devices.

### **Memory**

The TPS-12B/W, TPS-15B/W & TPS-17B/W touchpanels feature 128 MB DDR RAM and 32 MB Flash, with a built-in Compact Flash slot that allows flash memory expansion up to 160 MB.

### **Slimline Tiltcase Design**

The stylish tiltcase housing allows smooth tilt adjustment from 45 to 90 degrees and features an integral cable strain relief and rear cover to secure and hide the connections at the back of the touchpanel. Four backlit pushbuttons are also provided, allowing for quick access to commonly used functions.

### Internal Block Diagram

The following diagram represents the switching abilities of the TPS-12B/W, TPS-15B/W & TPS-17B/W. The diagram depicts the video, audio and connectivity paths available.

*Internal Block Diagram of the TPS-12B/W, TPS-15B/W & TPS-17B/W*

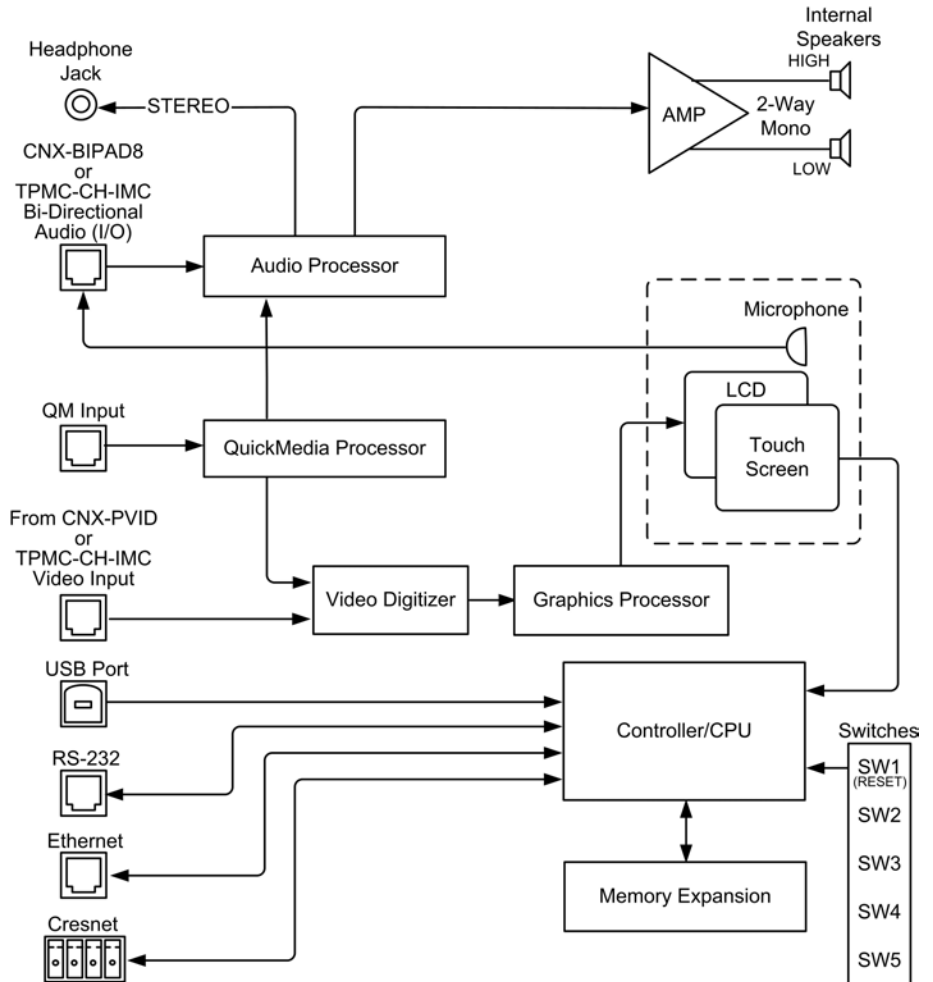



## Specifications

Specifications for the TPS-12B/W, TPS-15B/W & TPS-17B/W are listed in the following table.

### TPS-12B/W, TPS-15B/W & TPS-17B/W Specifications

| SPECIFICATION       | DETAILS  |
|---------------------|--|
| Touchscreen Display |  |
| Display Type        | TFT active matrix color LCD  |
| Size                | TPS-12B/W: 12 inch (30.5 cm) diagonal<br>TPS-15B/W: 15 inch (38.1 cm) diagonal<br>TPS-17B/W: 17 inch (43.2 cm) diagonal widescreen   |
| Aspect Ratio        | TPS-12B/W: 4:3 SVGA<br>TPS-15B/W: 4:3 XGA<br>TPS-17B/W: 15:9 WXGA  |
| Resolution          | TPS-12B/W: 800 x 600<br>TPS-15B/W: 1024 x 768<br>TPS-17B/W: 1280 x 768   |
| Brightness          | TPS-12B/W: 400 nits<br>TPS-15B/W: 400 nits<br>TPS-15B/W: 350 nits <sup>1</sup><br>TPS-17B/W: 450 nits  |
| Contrast            | TPS-12B/W: 300:1<br>TPS-15B/W: 300:1<br>TPS-15B/W: 700:1 <sup>1</sup><br>TPS-17B/W: 400:1  |
| Color Depth         | TPS-12B/W: 18-bit, 256k colors<br>TPS-15B/W: 24-bit, 16.7M colors<br>TPS-17B/W: 24-bit, 16.7M colors   |
| Illumination        | Backlit fluorescent  |
| Viewing Angle       | TPS-12B/W: ±70° horizontal, +45/-55° vertical<br>TPS-15B/W: ±85° horizontal and vertical<br>TPS-17B/W: ±88° horizontal and vertical  |
| Touchscreen         | Resistive membrane   |
| Processor           |  |
| CPU                 | 32-bit Freescale Coldfire® Microprocessor  |
| Processing Speed    | 410 MIPS (Dhrystone 2.1 benchmark)   |
| Memory              |  |
| DDR RAM             | 128 MB   |
| Flash               | 32 MB, expandable to 160 MB via compact flash  |
| Graphic Engine      | Isys engine, 24-bit non-palette graphics + 8-bit alpha channel translucence, 16.7 million colors, Synapse image rendering algorithm, multi-mode objects, dynamic graphics, full-motion (60 fps) animation, transition effects, color key video windowing |
| Ethernet            | 10BaseT/100BaseTX, auto-switching, auto-negotiating, full/half duplex, TCP/IP, UDP/IP, CIP, IEEE 802.3U compliant  |

(Continued on following page)

*TPS-12B/W, TPS-15B/W & TPS-17B/W Specifications (Continued)*

| SPECIFICATION  | DETAILS  |
|--|--|
| Video  |  |
| Signal Types   | Auto-detecting composite, S-video or component   |
| Formats  | NTSC 480i or PAL 576i  |
| Color Depth  | 24-bit, 16.7M colors   |
| Features   | Single-window scalable to full-screen, input switching between QM and VIDEO inputs, time base correction, gamma correction, line doubling, motion adaptive deinterlacing, reverse 3:2/2:2 pulldown |
| Audio  |  |
| Hardware Features  | Built-in microphone and amplified speakers, stereo headphone output, internal volume control and audio mixer   |
| Audio Feedback (WAV)   | 8-bit PCM, mono, 8 kHz sampling rate   |
| D-A Conversion (via QM only)                                   | 24-bit, 48 kHz   |
| Amplification  | Mono, 5 Watts x 2  |
| Power Requirements   |  |
| Cresnet Power Usage  | TPS-12B/W: 43 Watts (1.8 Amps @ 24 Volts DC)<br>TPS-15B/W: 65 Watts (2.7 Amps @ 24 Volts DC)<br>TPS-17B/W: 74 Watts (3.1 Amps @ 24 Volts DC)   |
| Default NET ID   | 03   |
| Minimum 2-Series Control System Update File <sup>2, 3, 4</sup> | Version 3.137 or later   |
| Timeout  | Adjustable from 0 to 120 minutes (Default = 10 minutes)  |
| Signal Join Maximum  | 4000 Digital, 4000 Analog, 999 Serial  |
| Environmental  |  |
| Temperature  | 41° to 113°F (5° to 45°C)  |
| Humidity   | 10% to 90% RH (non-condensing)   |
| Enclosure  |  |
| Construction   | Black or white high impact injection-molded case, tilt screen with adjustable tension, integral rear cover and cable strain relief in base   |
| Screen Tilt  | Adjustable 45 to 90 degrees  |
| Dimensions   |  |
| Height   | TPS-12B/W: 12.15 in (30.86 cm)<br>TPS-15B/W: 13.47 in (34.21 cm)<br>TPS-17B/W: 13.47 in (34.21 cm)   |
| Width  | TPS-12B/W: 12.85 in (32.64 cm)<br>TPS-15B/W: 14.94 in (37.85 cm)<br>TPS-17B/W: 17.63 in (44.78 cm)   |
| Depth  | TPS-12B/W: 12.40 in (31.50 cm)<br>TPS-15B/W: 12.40 in (31.50 cm)<br>TPS-17B/W: 12.40 in (31.50 cm)   |
| Weight   | TPS-12B/W: 12.95 lbs (5.88 kg)<br>TPS-15B/W: 14.55 lbs (6.60 kg)<br>TPS-17B/W: 18.10 lbs (8.21 kg)   |

*(Continued on following page)*

*TPS-12B/W, TPS-15B/W & TPS-17B/W Specifications (Continued)*

| SPECIFICATION  | DETAILS  |
|--|--|
| Available Models<br>TPS-12B<br>TPS-12W<br>TPS-15B<br>TPS-15W<br>TPS-17B<br>TPS-17W       | Isys 12" Tilt Touchpanel (Slimline), Black<br>Isys 12" Tilt Touchpanel (Slimline), White<br>Isys 15" Tilt Touchpanel (Slimline), Black<br>Isys 15" Tilt Touchpanel (Slimline), White<br>Isys 17" Tilt Touchpanel (Slimline), Black<br>Isys 17" Tilt Touchpanel (Slimline), White |
| Included Accessories<br>TPMC-CH-IMC <sup>5</sup>   | CAT5 Balanced AV Interface Module<br>(refer to TPMC-CH-IMC specifications for complete information)  |
| Available Accessories<br>TPMC-CH-IMW<br>TPS/TPMC-CBL-T<br>QM-TX<br>SMK-12/15/17<br>ST-PK | CAT5 Balanced AV Interface Wall Plate<br>Triamese Interface Cables (15 ft cable included)<br>QuickMedia Transmitter<br>Swivel Mount Kit<br>Programming Cable Kit   |

1. Applies to part number 6500191 and 6500194 only.
2. The latest software versions can be obtained from the Crestron website. Refer to the NOTE following these footnotes.
3. Crestron 2-Series control systems include the AV2 and PRO2. Consult the latest Crestron Product Catalog for a complete list of 2-Series control systems.
4. When loading VisionTools® Pro-e files or firmware through the RS-232 port of the control system, be sure that the baud rate is set to 38400 (Cresnet speed) or lower. Otherwise, Crestron Toolbox™ may post the "Transfer Failed" message.
5. For networks without CAT5 audio and video, the TPMC-CH-IMC is included to convert unbalanced video sent over coax cable and balanced/unbalanced audio sent over shielded, twisted-pair wiring to CAT5 cabling for connection to the touchpanels. The TPMC-CH-IMC is not for use with QuickMedia.

---

**NOTE:** Crestron software and any files on the website are for authorized Crestron dealers and Crestron Authorized Independent Programmers (CAIP) only. New users may be required to register to obtain access to certain areas of the site (including the FTP site).

---

## Physical Description

This section provides information on the connections, controls and indicators available on your TPS-12B/W, TPS-15B/W & TPS-17B/W.

### *TPS-12B Physical View*



### *TPS-15W Physical View*



### *TPS-17B Physical View*



*TPS-12B/W Overall Dimensions (Front View)*

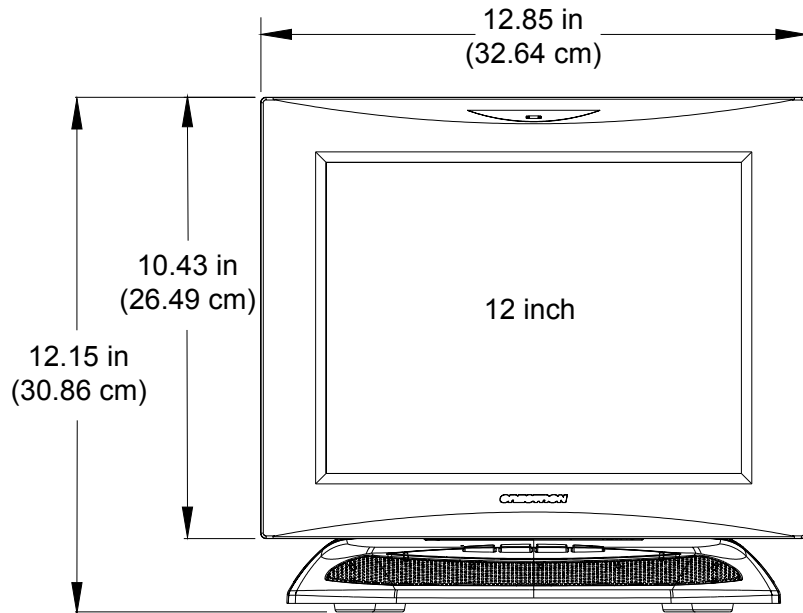

*TPS-12B/W Overall Dimensions (Side View at Maximum and Minimum Elevation)*

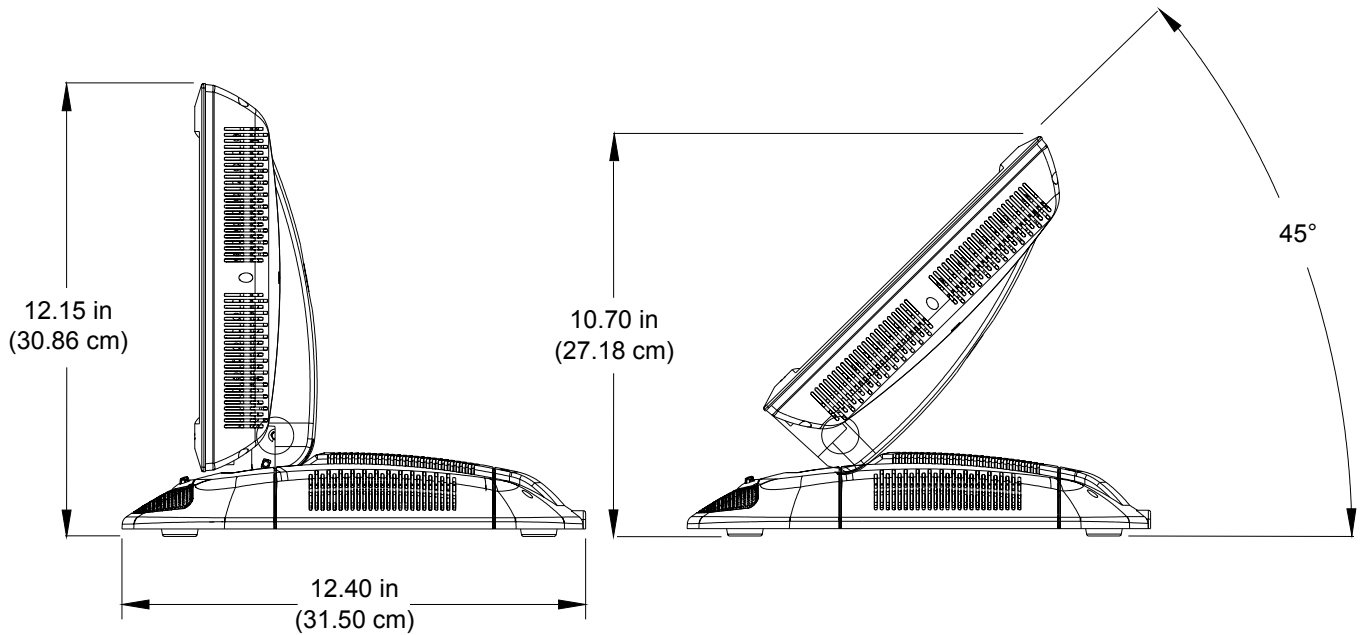

*TPS-15B/W Overall Dimensions (Front View)*

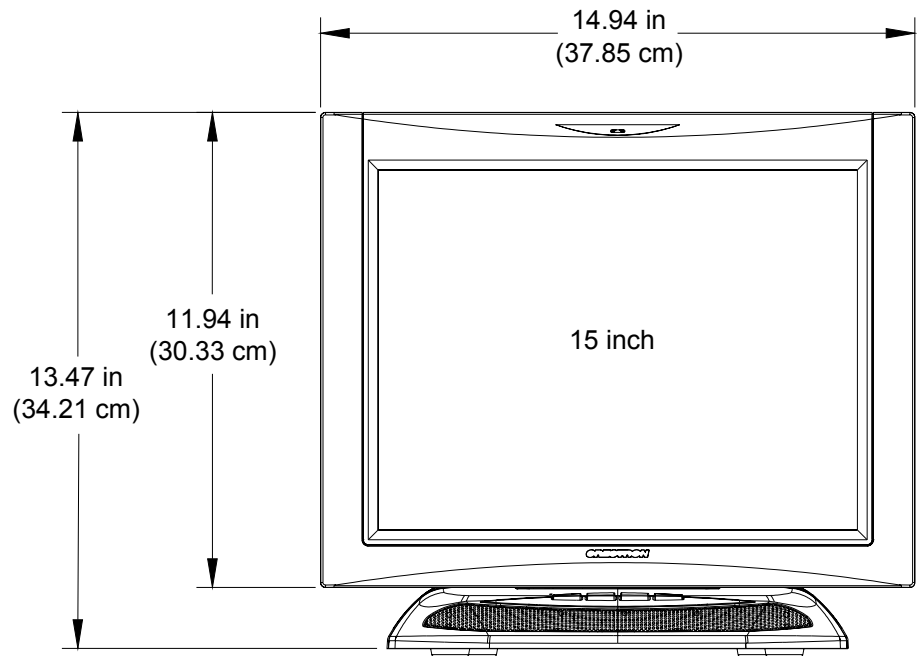

*TPS-17B/W Overall Dimensions (Front View)*

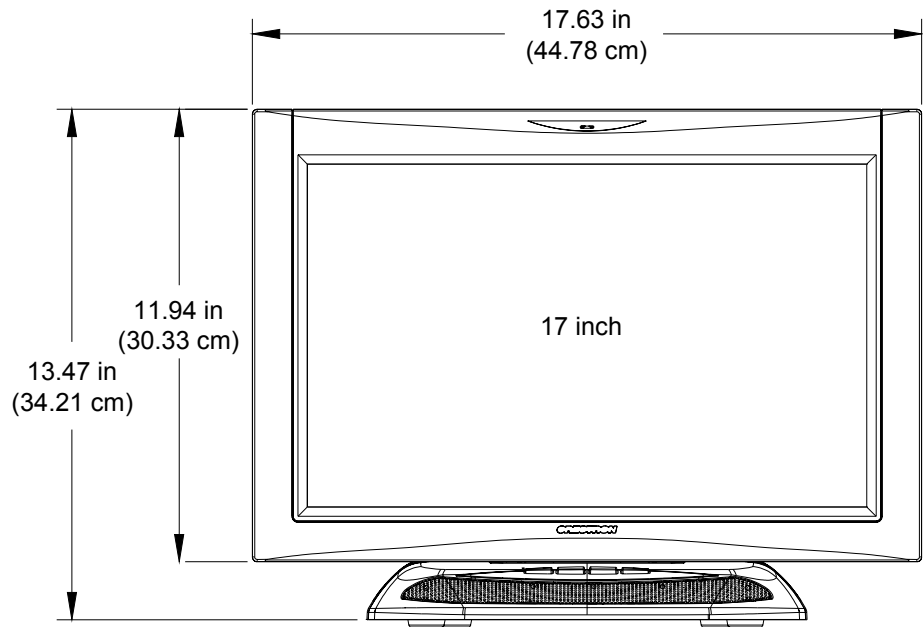

---

**NOTE:** The TPS-15BW and TPS-17BW are the same height.

---

*TPS-15B/W & TPS-17B/W Overall Dimensions (Side View at Maximum and Minimum Elevation)*

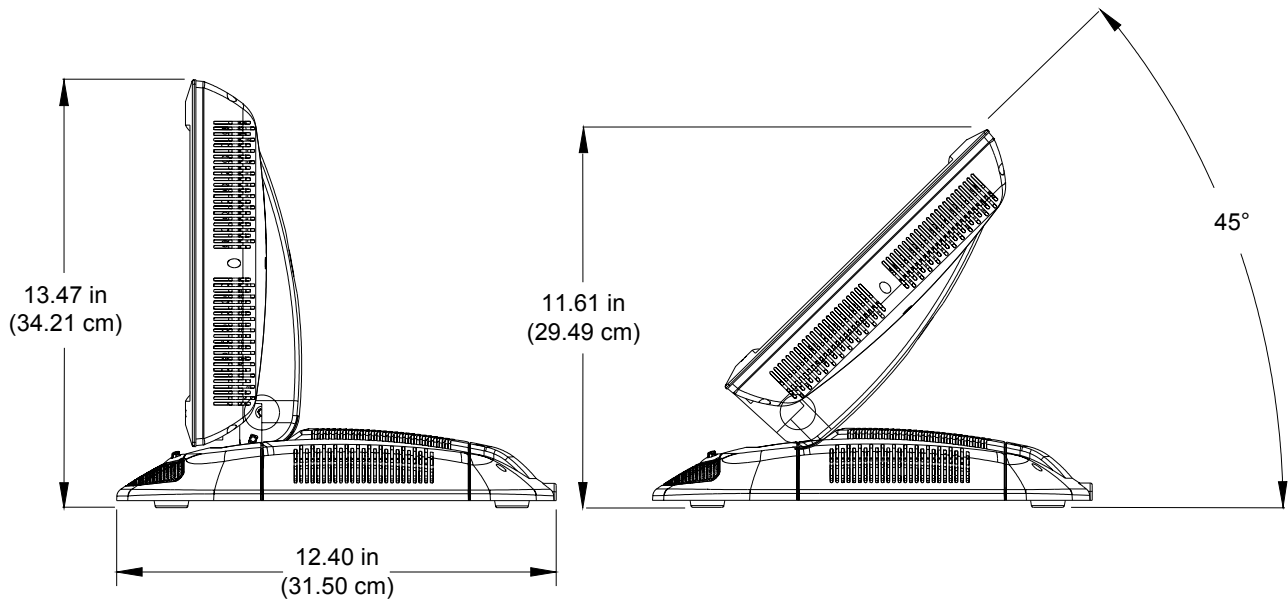



---

**NOTE:** All three touchpanels share an identical base unit.

---

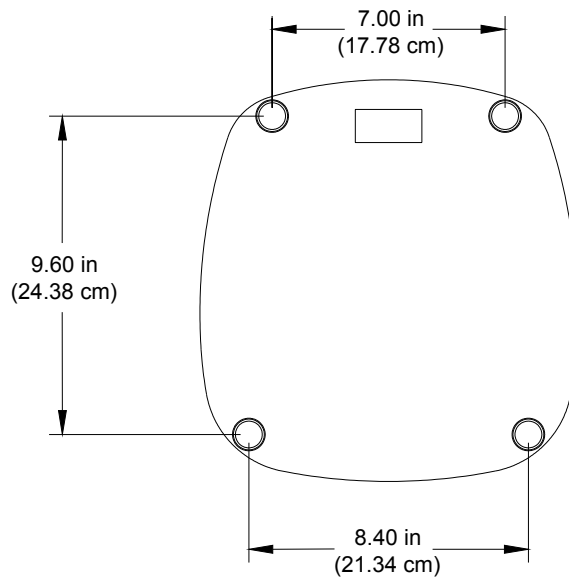
*Bottom View*



TPS-12B/W, TPS-15B/W & TPS-17B/W Pushbuttons

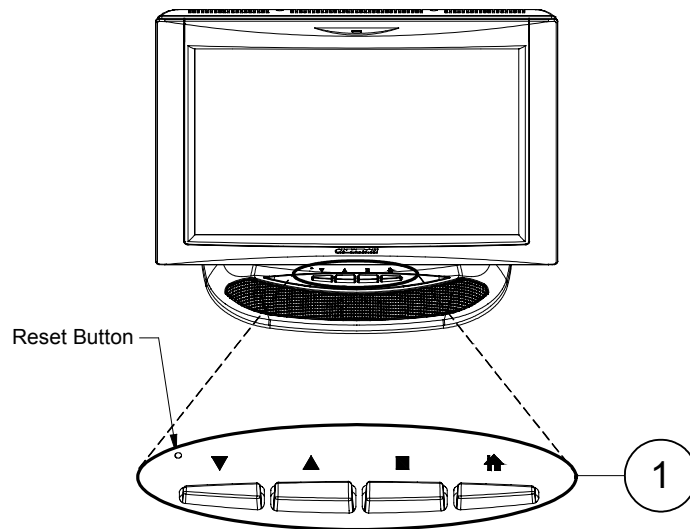

TPS-12B/W, TPS-15B/W & TPS-17B/W Connectors (Cover Removed)

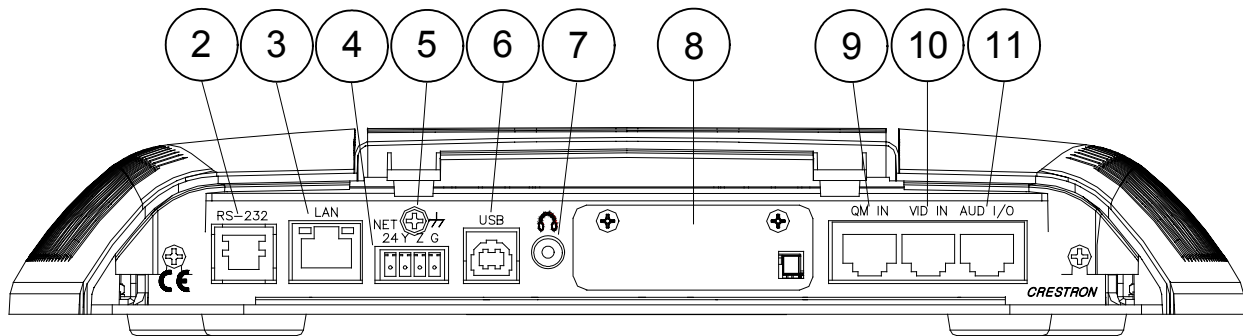

**NOTE:** All connections to the TPS-12B/W, TPS-15B/W & TPS-17B/W are made through the ports on the rear panel. These ports are not accessible after the cover is replaced.

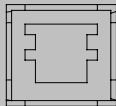

Connectors, Controls & Indicators

| # | CONNECTORS <sup>1</sup> ,<br>CONTROLS &<br>INDICATORS   | DESCRIPTION   |
|---|---|---|
| 1 | BUTTONS <sup>2</sup>  | (4) Backlit “softkey” buttons, programmable<br>(1) Backlit hard reset button, reboots the touchpanel.   |
| 2 | RS-232<br> | (1) 6-pin RJ-11 female;<br>Computer console, touch output or mouse/touch input port;<br>Bidirectional RS-232 up to 115.2k baud;<br>Hardware and software handshaking support. |

(Continued on following page)



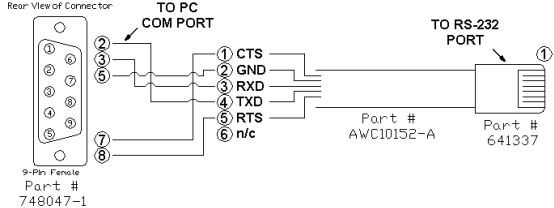
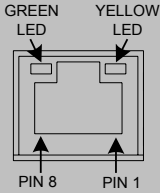
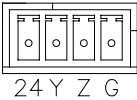

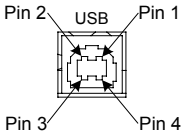

Connectors, Controls & Indicators (Continued)

| #     | CONNECTORS <sup>1</sup> , CONTROLS & INDICATORS  | DESCRIPTION   |        |             |     |        |   |        |   |        |   |        |   |      |   |                     |   |     |   |     |   |     |
|-------|--|---|--------|-------------|-----|--------|---|--------|---|--------|---|--------|---|------|---|---------------------|---|-----|---|-----|---|-----|
|       | RS-232<br>(Continued)  | <table border="1" data-bbox="922 342 1255 625"> <thead> <tr> <th>PIN #</th> <th>DESCRIPTION</th> </tr> </thead> <tbody> <tr><td>1</td><td>CTS</td></tr> <tr><td>2</td><td>GND</td></tr> <tr><td>3</td><td>RXD</td></tr> <tr><td>4</td><td>TXD</td></tr> <tr><td>5</td><td>RTS</td></tr> <tr><td>6</td><td>N/C (Not connected)</td></tr> </tbody> </table> <p data-bbox="922 642 1438 764">In the event that modular cables or an RJ-11 to DB9F adapter is not available, the following diagram provides information so that the cable can be fabricated on site. (Alternatively, Crestron cable number STCP-502PC is sold separately.)</p>  | PIN #  | DESCRIPTION | 1   | CTS    | 2 | GND    | 3 | RXD    | 4 | TXD    | 5 | RTS  | 6 | N/C (Not connected) |   |     |   |     |   |     |
| PIN # | DESCRIPTION  |   |        |             |     |        |   |        |   |        |   |        |   |      |   |                     |   |     |   |     |   |     |
| 1     | CTS  |   |        |             |     |        |   |        |   |        |   |        |   |      |   |                     |   |     |   |     |   |     |
| 2     | GND  |   |        |             |     |        |   |        |   |        |   |        |   |      |   |                     |   |     |   |     |   |     |
| 3     | RXD  |   |        |             |     |        |   |        |   |        |   |        |   |      |   |                     |   |     |   |     |   |     |
| 4     | TXD  |   |        |             |     |        |   |        |   |        |   |        |   |      |   |                     |   |     |   |     |   |     |
| 5     | RTS  |   |        |             |     |        |   |        |   |        |   |        |   |      |   |                     |   |     |   |     |   |     |
| 6     | N/C (Not connected)  |   |        |             |     |        |   |        |   |        |   |        |   |      |   |                     |   |     |   |     |   |     |
| 3     | <p data-bbox="755 1010 802 1031">LAN</p>              | <p data-bbox="930 1010 1360 1115">(1) 8-wire RJ-45 with two LED indicators; 10BaseT/100BaseTX Ethernet port; Green LED indicates link status; Yellow LED indicates Ethernet activity.</p> <table border="1" data-bbox="922 1146 1419 1297"> <thead> <tr> <th>PIN</th> <th>SIGNAL</th> <th>PIN</th> <th>SIGNAL</th> </tr> </thead> <tbody> <tr><td>1</td><td>TX +</td><td>5</td><td>N/C</td></tr> <tr><td>2</td><td>TX -</td><td>6</td><td>RC -</td></tr> <tr><td>3</td><td>RC+</td><td>7</td><td>N/C</td></tr> <tr><td>4</td><td>N/C</td><td>8</td><td>N/C</td></tr> </tbody> </table>  | PIN    | SIGNAL      | PIN | SIGNAL | 1 | TX +   | 5 | N/C    | 2 | TX -   | 6 | RC - | 3 | RC+                 | 7 | N/C | 4 | N/C | 8 | N/C |
| PIN   | SIGNAL   | PIN   | SIGNAL |             |     |        |   |        |   |        |   |        |   |      |   |                     |   |     |   |     |   |     |
| 1     | TX +   | 5   | N/C    |             |     |        |   |        |   |        |   |        |   |      |   |                     |   |     |   |     |   |     |
| 2     | TX -   | 6   | RC -   |             |     |        |   |        |   |        |   |        |   |      |   |                     |   |     |   |     |   |     |
| 3     | RC+  | 7   | N/C    |             |     |        |   |        |   |        |   |        |   |      |   |                     |   |     |   |     |   |     |
| 4     | N/C  | 8   | N/C    |             |     |        |   |        |   |        |   |        |   |      |   |                     |   |     |   |     |   |     |
| 4     | <p data-bbox="755 1318 802 1339">NET</p>              | <p data-bbox="930 1318 1446 1371">Four-position terminal block connector for data and power. Connects to Cresnet control network.</p> <p data-bbox="971 1371 1166 1476">Pin 1 (24) Power<br/>Pin 2 (Y) Data<br/>Pin 3 (Z) Data<br/>Pin 4 (G) Ground</p>   |        |             |     |        |   |        |   |        |   |        |   |      |   |                     |   |     |   |     |   |     |
| 5     | <p data-bbox="768 1493 784 1514">G</p>                | <p data-bbox="930 1493 1295 1518">(1) 6-32 screw, chassis ground lug.</p>   |        |             |     |        |   |        |   |        |   |        |   |      |   |                     |   |     |   |     |   |     |
| 6     | <p data-bbox="755 1566 802 1587">USB<sup>3</sup></p>  | <p data-bbox="930 1566 1271 1619">(1) USB Type B female (reserved for future applications)</p> <table border="1" data-bbox="922 1644 1263 1822"> <thead> <tr> <th>PIN</th> <th>DESCRIPTION</th> </tr> </thead> <tbody> <tr><td>1</td><td>+5 VDC</td></tr> <tr><td>2</td><td>Data -</td></tr> <tr><td>3</td><td>Data +</td></tr> <tr><td>4</td><td>Ground</td></tr> </tbody> </table>  | PIN    | DESCRIPTION | 1   | +5 VDC | 2 | Data - | 3 | Data + | 4 | Ground |   |      |   |                     |   |     |   |     |   |     |
| PIN   | DESCRIPTION  |   |        |             |     |        |   |        |   |        |   |        |   |      |   |                     |   |     |   |     |   |     |
| 1     | +5 VDC   |   |        |             |     |        |   |        |   |        |   |        |   |      |   |                     |   |     |   |     |   |     |
| 2     | Data -   |   |        |             |     |        |   |        |   |        |   |        |   |      |   |                     |   |     |   |     |   |     |
| 3     | Data +   |   |        |             |     |        |   |        |   |        |   |        |   |      |   |                     |   |     |   |     |   |     |
| 4     | Ground   |   |        |             |     |        |   |        |   |        |   |        |   |      |   |                     |   |     |   |     |   |     |

(Continued on following page)

*Connectors, Controls & Indicators (Continued)*

| #  | CONNECTORS <sup>1</sup> ,<br>CONTROLS &<br>INDICATORS   | DESCRIPTION  |
|----|---|--|
| 7  | HEADPHONES <sup>4</sup><br>      | (1) 3.5 mm TRS mini phone jack;<br>Output power: 12 mW per channel;<br>Minimum impedance: 32 Ω.  |
| 8  | MEMORY SLOT   | (1) Type II Compact Flash card slot for memory expansion (up to 160 MB).   |
| 9  | QM IN <sup>5, 6, 7, 8</sup><br>  | (1) 8-wire RJ-45 female, QuickMedia input port;<br>Signal types: Auto-detecting component (YP <sub>b</sub> P <sub>r</sub> ), S-video (Y/C) or composite video with stereo program audio and (2) microphone channels;<br>Video formats: NTSC 480i or PAL 576i;<br>Connects to QM output port of a QM-TX or other QuickMedia device via CresCAT-QM or CresCAT-IM cable;<br>Maximum cable length: 300 feet (aggregate distance from QM origination).  |
| 10 | VIDEO IN <sup>6, 9, 10</sup><br> | (1) 8-wire RJ-45 female, CAT5 balanced video input port;<br>Signal types: Auto-detecting component (YP <sub>b</sub> P <sub>r</sub> ), S-video (Y/C) or composite video;<br>Video formats: NTSC 480i or PAL 576i;<br>Input impedance: 100 Ω balanced;<br>Connects to any Crestron CAT5 balanced video source or TPMC-CH-IMC interface module (included) via CresCAT® cable or TPS/TPMC-CBL-T “triamese” cable (included);<br>Maximum cable length: 500 feet (component), 750 feet (S-video or composite).                                     |
| 11 | AUDIO I/O <sup>9, 11</sup><br> | (1) 8-wire RJ-45 female, bidirectional CAT5 balanced audio port;<br>Signal type: receives (1) balanced stereo audio signal and transmits (1) balanced stereo audio signal from internal microphone;<br>Maximum input level: 4 V <sub>rms</sub> ;<br>Maximum output level: 2 V <sub>rms</sub> ;<br>Input/output impedance: 600 Ω;<br>Connects to any other Crestron CAT5 balanced audio port or TPMC-CH-IMC interface module (included) via CresCAT® cable or TPS/TPMC-CBL-T “triamese” cable (included);<br>Maximum cable length: 1000 feet. |

1. Interface connectors for NET and some TPMC-CH-IMC ports are provided with the unit.
2. Refer to “Hard Button Programming” on page 45 for details.
3. This connector is reserved for future applications.
4. Plugging in headphones will mute the built-in speakers.
5. The QM port is not connected through any “IMC” interface.
6. Only one video source may be displayed at a time.
7. Does not support RGB.

8. The eight-pin RJ-45 QuickMedia transport port accepts CAT5E/CAT6 carrying audio, video and microphone signals. The QM input port conforms to the 568B wiring standard. Refer to the following table for connector pinouts.

| RJ-45 PIN NUMBER | WIRE COLORS (EIA 568B) | QM ASSIGNMENT COMPOSITE, S-VIDEO, COMPONENT AND AUDIO |
|------------------|------------------------|---|
| 1                | WHITE/ORANGE           | - CHROMINANCE (- P <sub>r</sub> )                     |
| 2                | ORANGE                 | + CHROMINANCE (+ P <sub>r</sub> )                     |
| 3                | WHITE/GREEN            | - LUMINANCE (- Y)                                     |
| 4                | BLUE                   | + AUDIO   |
| 5                | WHITE/BLUE             | - AUDIO   |
| 6                | GREEN                  | + LUMINANCE (+ Y)                                     |
| 7                | WHITE/BROWN            | - COMPOSITE (- P <sub>b</sub> )                       |
| 8                | BROWN                  | + COMPOSITE (+ P <sub>b</sub> )                       |

9. Use only the TPMC-CH-IMC Interface Module when connecting this port. Use of other “IMC” products could damage the panel.
10. This eight-pin RJ-45 port provides connectivity to the CNX-PVID or the TPMC-CH-IMC Interface Module. This port provides component, composite or S-video balanced input to the touchpanel over CAT5 wiring. Refer to the following table for connector pinouts.

| PIN | WIRE COLORS (568B) | COMPOSITE   | S-VIDEO       | COMPONENT        |
|-----|--------------------|-------------|---------------|------------------|
| 1   | WHITE/ORANGE       | + Composite | + Luminance   | + Y              |
| 2   | ORANGE             | - Composite | - Luminance   | - Y              |
| 3   | WHITE/GREEN        | N/A         | + Chrominance | + P <sub>b</sub> |
| 4   | BLUE               | N/A         | N/A           | + P <sub>r</sub> |
| 5   | WHITE/BLUE         | N/A         | N/A           | - P <sub>r</sub> |
| 6   | GREEN              | N/A         | - Chrominance | - P <sub>b</sub> |
| 7   | WHITE/BROWN        | N/A         | N/A           | N/A              |
| 8   | BROWN              | N/A         | N/A           | N/A              |

11. This eight-pin RJ-45 port provides connectivity to the CNX-BIPAD or the TPMC-CH-IMC Interface Module. This port uses CAT5 wiring and provides audio input to the touchpanel and output from the touchpanel’s built-in microphone. Refer to the following table for connector pinouts.

| PIN | WIRE COLORS (568B) | AUDIO I/O        |
|-----|--------------------|------------------|
| 1   | WHITE/ORANGE       | + Mic Left Out   |
| 2   | ORANGE             | - Mic Left Out   |
| 3   | WHITE/GREEN        | + Mic Right Out  |
| 4   | BLUE               | + Audio Left In  |
| 5   | WHITE/BLUE         | - Audio Left In  |
| 6   | GREEN              | - Mic Right Out  |
| 7   | WHITE/BROWN        | + Audio Right In |
| 8   | BROWN              | - Audio Right In |

## Industry Compliance

As of the date of manufacture the TPS-12B/W, TPS-15B/W & TPS-17B/W have been tested and found to comply with specifications for CE marking and standards per EMC and Radiocommunications Compliance Labelling.



---

**NOTE:** This device complies with part 15 of the FCC rules. Operation is subject to the following two conditions: (1) this device may not cause harmful interference and (2) this device must accept any interference received, including interference that may cause undesired operation.

This equipment has been tested and found to comply with the limits for a Class B digital device, pursuant to part 15 of the FCC Rules. These limits are designed to provide reasonable protection against harmful interference in a residential installation. This equipment generates, uses and can radiate radio frequency energy and if not installed and used in accordance with the instructions, may cause harmful interference to radio communications. However, there is no guarantee that interference will not occur in a particular installation. If this equipment does cause harmful interference to radio or television reception, which can be determined by turning the equipment off and on, the user is encouraged to try to correct the interference by one or more of the following measures:

- Reorient or relocate the receiving antenna.
  - Increase the separation between the equipment and receiver.
  - Connect the equipment into an outlet on a circuit different from that to which the receiver is connected.
  - Consult the dealer or an experienced radio/TV technician for help.
-

---

## Setup

### Network Wiring

When wiring the network, consider the following:

- Use Crestron Certified Wire.
- Use Crestron power supplies for Crestron equipment.
- Provide sufficient power to the system.

---

**CAUTION:** Insufficient power can lead to unpredictable results or damage to the equipment. Please use the Crestron Power Calculator to help calculate how much power is needed for the system (<http://www.crestron.com/calculators>).

---

- For larger networks, use a Cresnet Hub/Repeater (CNXHUB) to maintain signal quality.

For more details, refer to “Check Network Wiring” on page 51.

### Ethernet

The TPS-12B/W, TPS-15B/W & TPS-17B/W also use high-speed Ethernet for communications between the device and a control system, computer, digital media server and other IP-based devices.

For information on connecting Ethernet devices in a Crestron system, refer to the latest version of the Crestron e-Control® Reference Guide (Doc. 6052).

### CAT5 Wiring

Category 5 (CAT5) wiring is a twisted pair cable designed for Ethernet networks. These networks operate at speeds of up to 100 Megabits per second (Mbps) using the 100BaseT standard. Crestron takes advantage of this specification for a variety of audio and video applications.

Crestron recommends using CresCAT, CresCAT-D or CresCAT-Q wiring solutions.

The following chart shows the maximum recommended cable lengths for various signal formats.

*Recommended Maximum Cable Lengths for Audio/Video via Crestron Certified Wire*

| FORMAT    | MAXIMUM DISTANCE |
|-----------|------------------|
| Composite | 750 feet         |
| S-Video   | 750 feet         |
| Component | 500 feet         |
| Audio     | 1000 feet        |

For more information, refer to the latest version of the Crestron CAT5 Wiring Reference Guide (Doc. 6137).

## QuickMedia Wiring

The Crestron QuickMedia cable (sold under the name “CresCAT-QM”) contains one CAT5E cable and one Cresnet cable in Siamese jackets. Installation of any QM device is as simple as installing CresCAT-QM wires from the output of one device to the input of another. Installations are flexible, affordable and fast. For more information, refer to the latest revision of the Crestron MediaManager Applications Guide (Doc. 6244).

### *CresCAT-QM Cable*

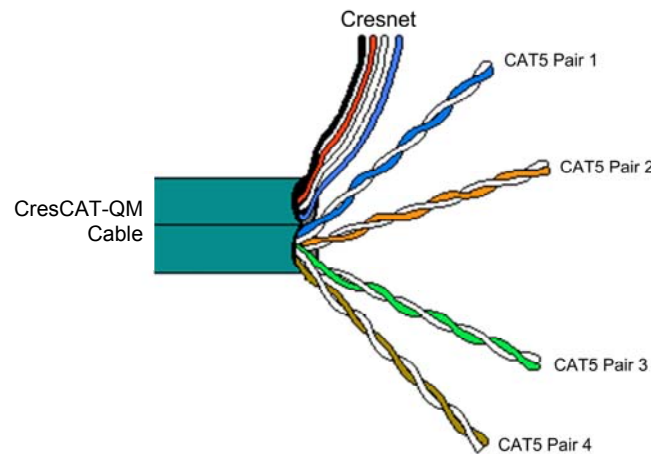

---

**NOTE:** Do not untwist the two wires in a single pair for more than 1/3-1/2” (0.84-1.27 cm) when making a connection. The twists are critical to canceling out interference between the wires.

---

The aggregate cable length of a signal path originating at a QM transmitter and terminating at the TPS-12B/W, TPS-15B/W & TPS-17B/W must not exceed 300 feet (90 meters). Video signals may experience a loss of quality over very long lengths of cable. This phenomenon is due to the added resistance and capacitance of longer cable lengths and is not peculiar to either Crestron and/or QuickMedia systems. To ensure sufficient bandwidth, the maximum aggregate cable length should not exceed 300 feet. The use of lower-resolution signals may allow increased cable length but must be tested by the installer with the sources to be used. The QM pin assignment is based on the EIA/TIA 568B RJ-45 Jack standard.

---

**NOTE:** When using CresCAT-QM wiring, four additional wires are included for making Cresnet® connections.

---

When connecting multiple QM devices, the route between a QM origination point (transmitter) and a QM endpoint (receiver) cannot have more than two midpoints (e.g. QM-MD7x2 or other QM switchers). Refer to the diagram on the following page when configuring a QM network.

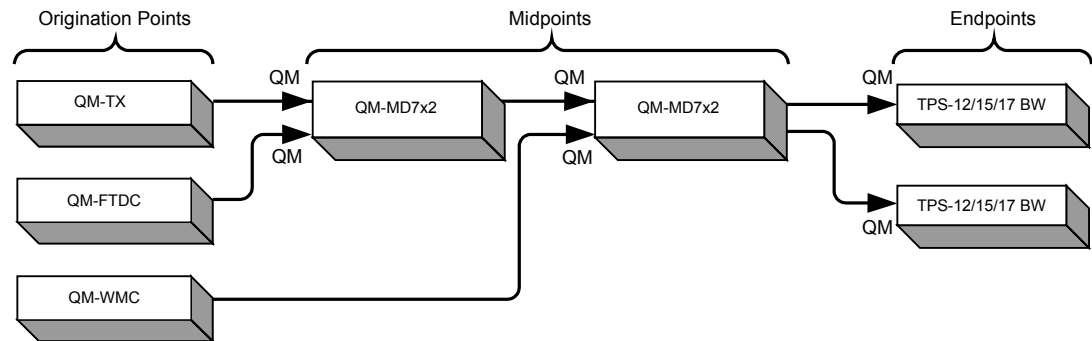
**QM Network Topology****Identity Code****Net ID**

The Net ID of the TPS-12B/W, TPS-15B/W & TPS-17B/W has been factory set to **03**. The Net IDs of multiple TPS-12B/W, TPS-15B/W & TPS-17B/W devices in the same system must be unique. The NET ID is set using the internal setup menu (refer to “Interface Menu” on page 22). Net ID may also be set from a personal computer (PC) via the Crestron Toolbox™ (refer to “Establishing Communication” on page 47).

When setting the Net ID, consider the following:

- The Net ID of each unit must match an ID code specified in the SIMPL Windows program.
- Each network device must have a unique Net ID.

For more details, refer to the Crestron Toolbox help file.

**IP ID**

The IP ID is set within the TPS-12B/W, TPS-15B/W & TPS-17B/W’s table using Crestron Toolbox. For information on setting an IP table, refer to the Crestron Toolbox help file. The IP IDs of multiple TPS-12B/W, TPS-15B/W & TPS-17B/W devices in the same system must be unique.

When setting the IP ID, consider the following:

- The IP ID of each unit must match an IP ID specified in the SIMPL Windows program.
- Each device using IP to communicate with a control system must have a unique IP ID.

## Configuring the Touchpanel

**NOTE:** The only connection required to configure the touchpanel is power (supplied via Cresnet). Refer to “Hardware Hookup” on page 35 for details.

To configure the unit it may be necessary to access a series of setup screens prior to viewing run-time screens that are loaded into the touchpanel for normal operation. The MAIN MENU for configuring the touchpanel appears when a finger is held to the touchscreen as power is applied or after the hardware reset button is pressed and released. Remove your finger when the message "SETUP MODE" briefly appears on the touchscreen.

Upon entering SETUP MODE the MAIN MENU, as shown in the following illustration, displays four buttons: **Touch Screen Calibration**, **Exit and Run Program**, **Setup** and **Diagnostics**.

The **Exit and Run Program** button verifies that all of the setup information has been saved to the EEPROM and displays the main page that has been programmed into your system. The remaining buttons on the MAIN MENU open other menus which are discussed in subsequent paragraphs.

### MAIN MENU

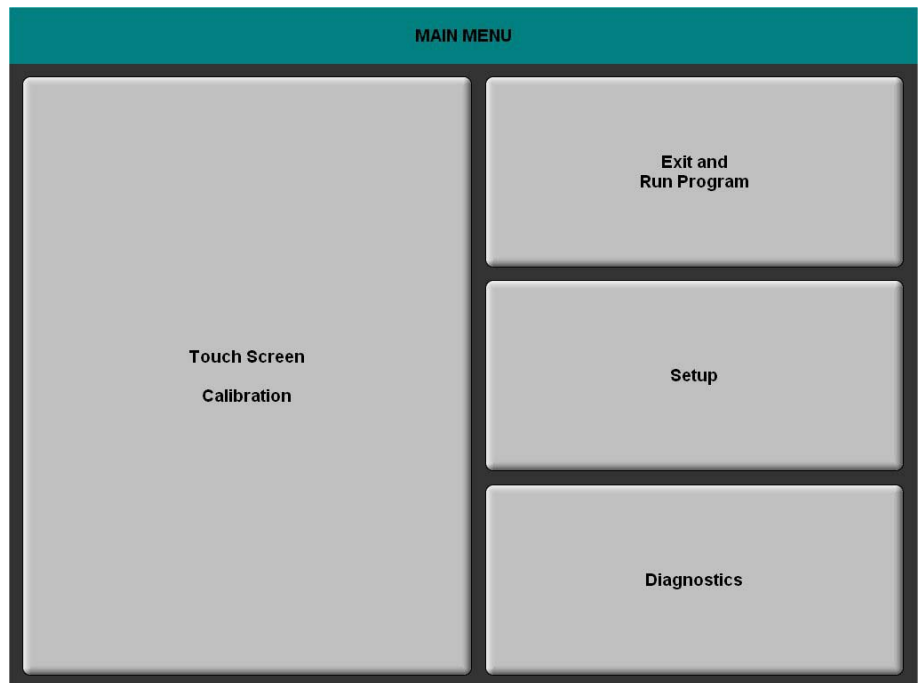



## Calibration Menu

### CALIBRATION MENU

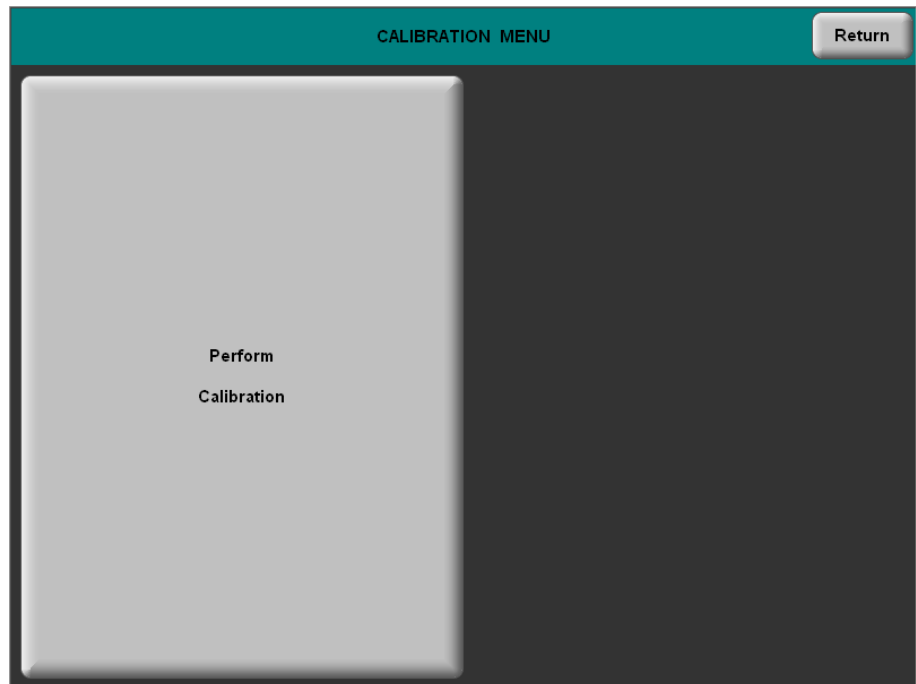

Touch **Perform Calibration**. The message “Touch Upper Left” appears centered on the panel with a cross hair in the upper left corner. Touch the center of the cross hair in the corner of the screen to initiate calibration. Another message, “Touch Upper Right”, appears with a cross hair in the correct corner. Touch the center of the cross hair in the corner of the screen. A final message, “Touch Lower Right”, appears with a cross hair in the correct corner. Touch the center of the cross hair in the corner of the screen to conclude calibration and return to the CALIBRATION MENU.

---

**NOTE:** When touching the screen during calibration be as accurate as possible. Use the tip of a capped pen or the eraser end of a pencil. To cancel calibration and return to the CALIBRATION MENU without saving calibration data, create a calibration error by touching the screen in the same spot three times.

---

### Setup Menu

To obtain the SETUP MENU press the **Setup** button from the MAIN MENU. The SETUP MENU offers a series of buttons which open additional menus and displays and are detailed in subsequent paragraphs. The SETUP MENU also provides **Down/Up** buttons to control *Screen Brightness*, *Key Backlight* and *Standby Timeout*. The *Hardkey Test Results* indicators will light when each respective button is pushed on the touchpanel. After setup parameters have been selected, select the **Return** button to return to the MAIN MENU.

**NOTE:** For convenience the current CRESNET ID setting is displayed in the upper left corner.

**NOTE:** All touchpanel settings are automatically saved in non-volatile memory.

#### SETUP MENU

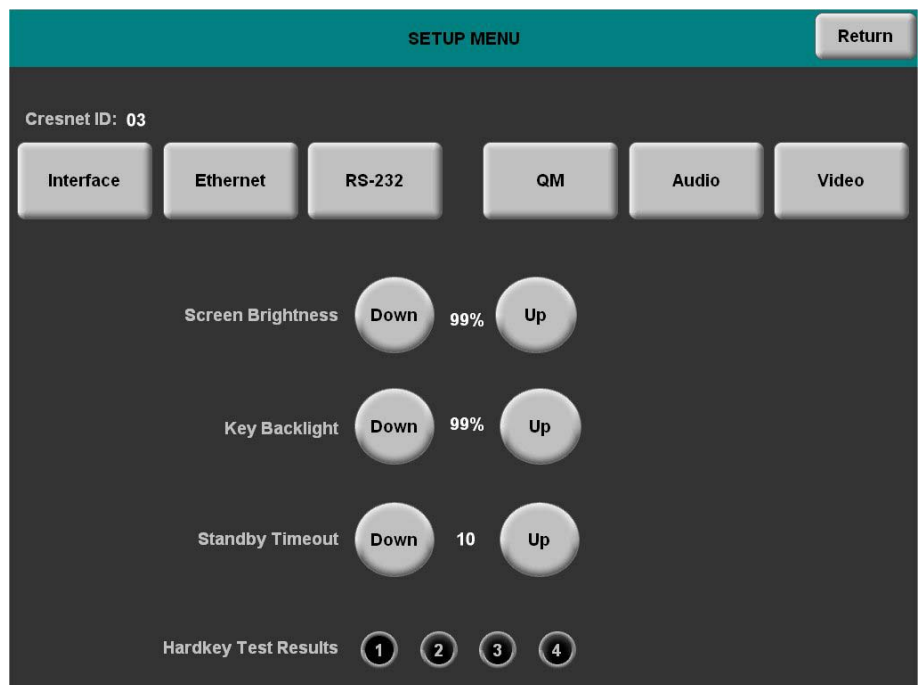

### Interface Menu

The touchpanel communicates with a control system to activate commands or to display feedback from components within the system. The communication interface must be correctly specified or communication will not occur. To set communication parameters select the **Interface** button located on the SETUP MENU and display the INTERFACE MENU, shown after this paragraph.

The Cresnet network identity number (CRESNET ID also known as the Net ID) is displayed on the INTERFACE MENU. Net ID is the two-digit hexadecimal number. The hexadecimal number can range from 03 to FE and must correspond to the Net ID set in the SIMPL Windows program of the Cresnet system. Matching IDs between touchpanel and SIMPL Windows program is required if data is to be successfully transferred. Net ID for the TPS-12B/W, TPS-15B/W & TPS-17B/W is factory set to 03. No two devices in the same system can have the same Net ID.

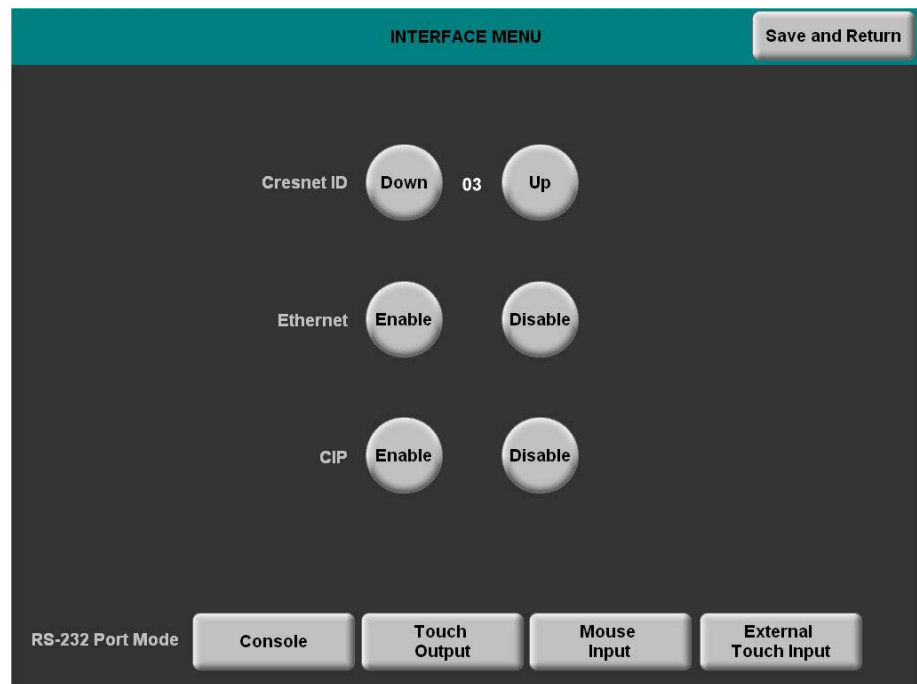
*INTERFACE MENU*

Two buttons adjacent to the hexadecimal display, **DOWN** and **UP**, decrease and increase the Net ID by one, respectively.

The four buttons at the bottom define how the RS-232 port can be used; as a console port (i.e. loading touchpanel projects and firmware), a touch output port (communication of touch coordinates to an external device), a mouse input port (allows a mouse to control the touchpanel) and an external touch input (allows another device to control the touchpanel).

The Ethernet **Enable** and **Disable** buttons determine the status of the touchpanel's Ethernet communications.

---

**NOTE:** The TPS-12B/W, TPS-15B/W & TPS-17B/W do not support a wireless Ethernet connection.

---

There may be Ethernet devices (i.e. a control system) on the network that communicates with the touchpanel via CIP (Cresnet Internet Protocol). Two buttons located on the INTERFACE MENU determine if the touchpanel is capable of this type of communication. Select **Enable** to permit this protocol recognition and **Disable** to prohibit any CIP connection. CIP must be enabled for the touchpanel to communicate with other Crestron Ethernet devices.

Select the **Save and Return** button located on the INTERFACE MENU to save changes and return to the SETUP MENU.

*Ethernet Setup Menu*

Selection of the **Ethernet** button from the SETUP MENU displays the ETHERNET SETUP MENU. This menu provides buttons for **Ethernet Status Test** (for details such as the IP Address, Subnet Mask, Default Router, IP Table, etc.), **DHCP Enable/Disable** and **Static IP Options**. Each of the **Static IP Options** has its own menu, as shown in the illustrations on the following pages. The enable/disable Ethernet feature is provided on the INTERFACE MENU. Ethernet settings are made

through Crestron Toolbox. Refer to the TCP/IP Communications section of “Establishing Communication”, which starts on page 47 for additional Ethernet setup details.

*ETHERNET SETUP MENU*

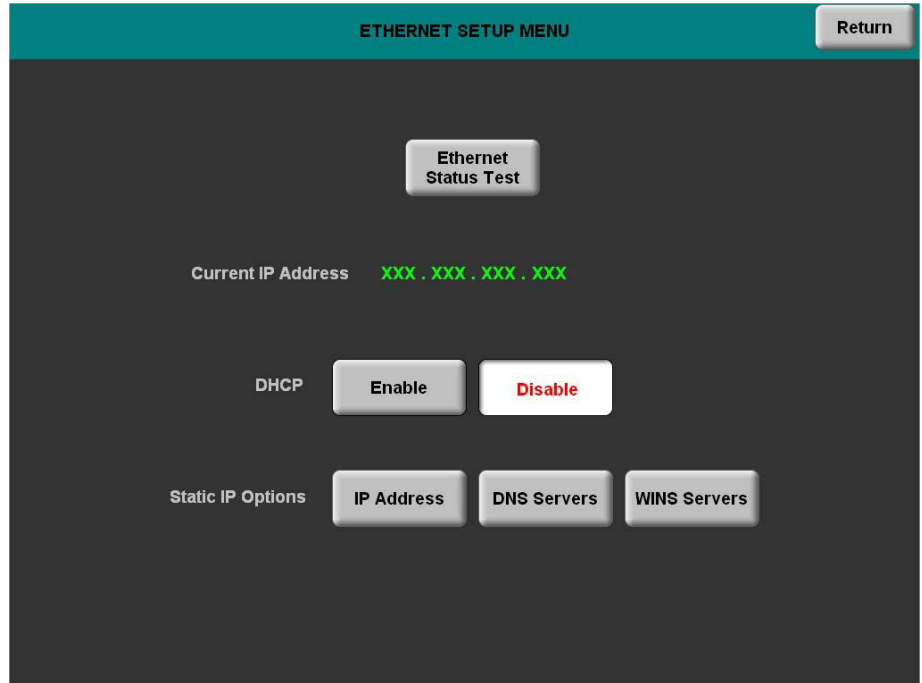

*ETHERNET STATIC IP SETTINGS*

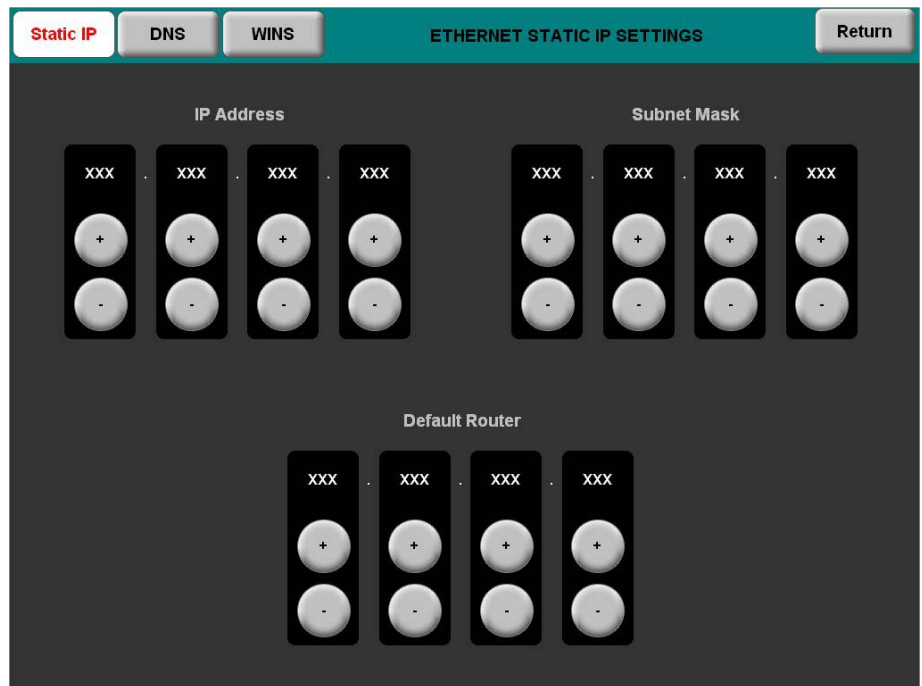

*ETHERNET DNS SETTINGS*

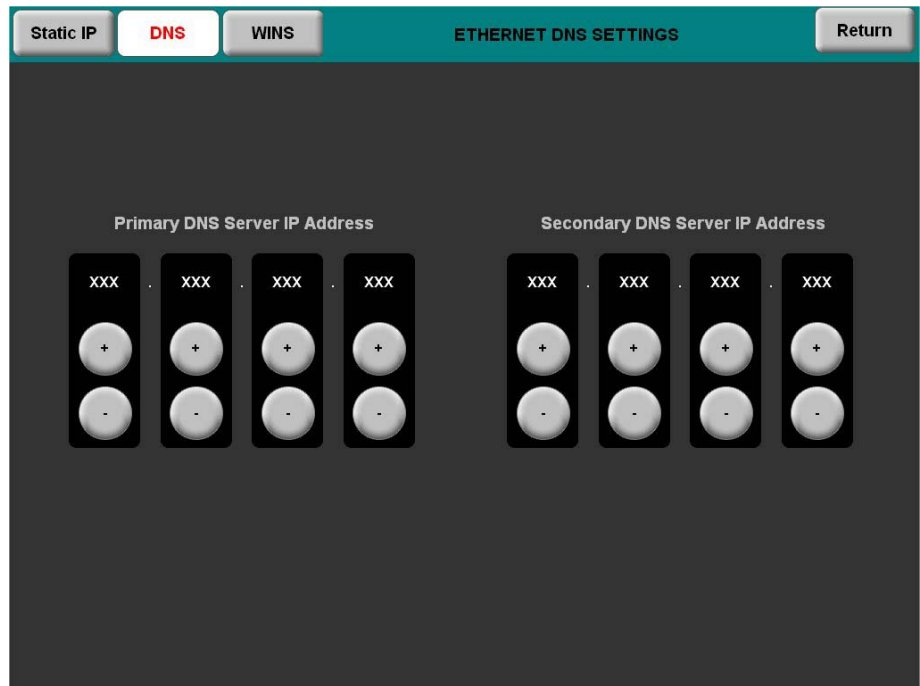

*ETHERNET WINS SETTINGS*

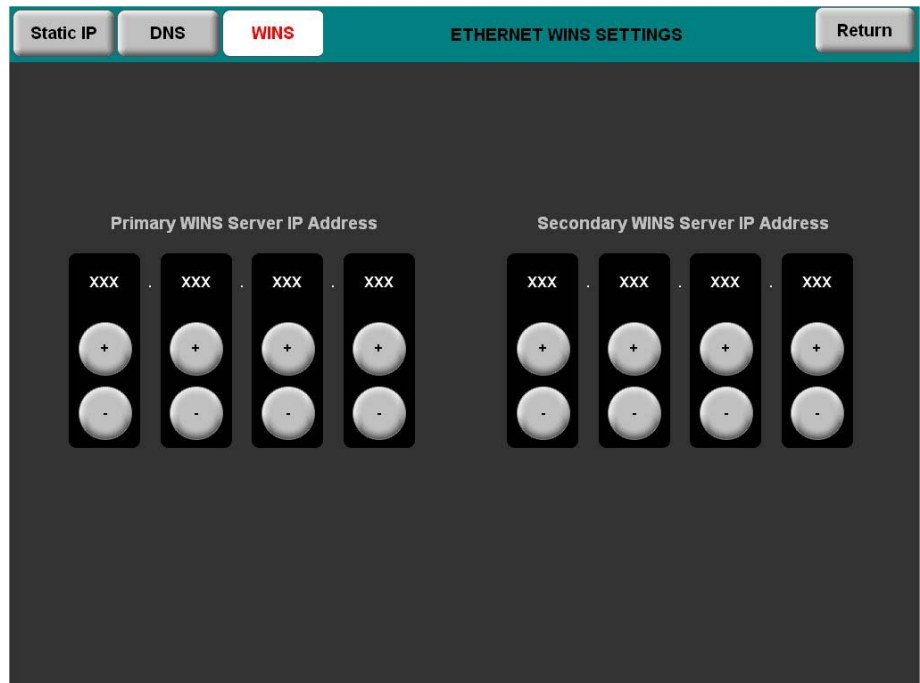

Selection of the DHCP **Enable** button from the ETHERNET SETUP MENU displays the DHCP options **Renew** and **Release**.

*ETHERNET SETUP MENU (DHCP ENABLED)*

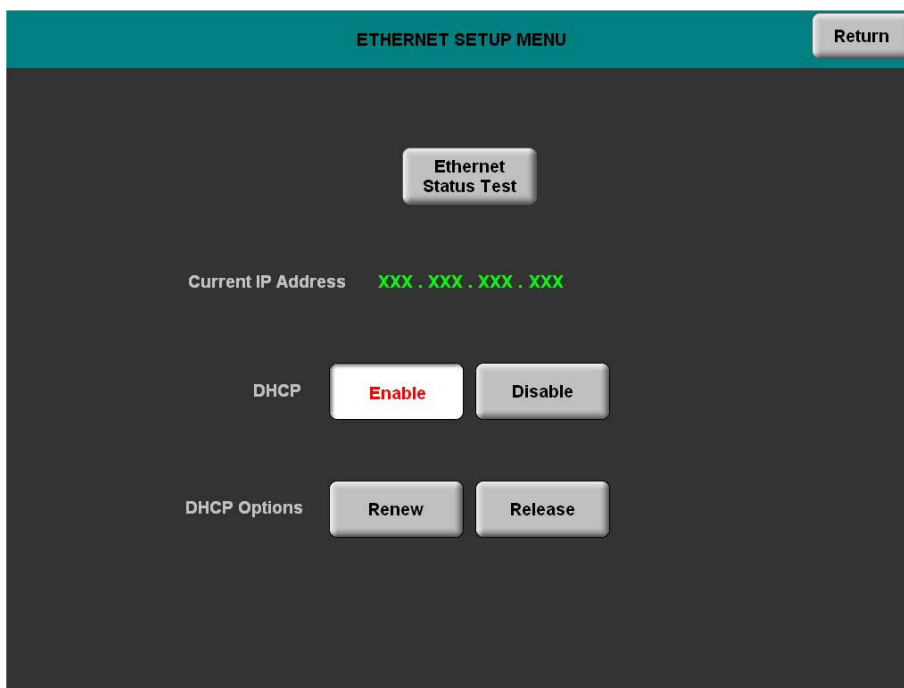

### RS-232 Menu

The touchpanel allows for one of four RS-232 communication modes:

- **Console** (i.e. loading projects and firmware)
- **Touch Output** (communication of touch coordinates to an external device)
- **Mouse Input** (allows a mouse to control the touchpanel)
- **External Touch Input** (allows another device to control the touchpanel)

For convenience the RS-232 MENU also permits the selection of the RS-232 communication options Baud Rate, Data Bits, Stop Bits, Parity, RTS On/Off and XON-XOFF On/Off.

Touch the communication option to select communication parameters and then select **Save and Return** to save the RS-232 settings and return to the SETUP MENU.

Default settings: Console mode, Baud Rate: 115200, data bits: 8, stop bits: 1, parity: none, RTS off and XON/XOFF off.

### *RS-232 MENU*

The screenshot shows the RS-232 MENU interface. At the top right is a "Save and Return" button. The menu is divided into several sections:

- Baud Rate:** A 3x3 grid of buttons with values: 300, 1200, 2400 (top row); 4800, 9600, 19200 (middle row); 38400, 57600, 115200 (bottom row).
- Data Bits:** Buttons for 7 and 8.
- Stop Bits:** Buttons for 1 and 2.
- Parity:** Buttons for None, Odd, and Even.
- RTS:** Buttons for Off and On.
- XON - XOFF:** Buttons for Off and On.
- RS-232 Port Mode:** Four buttons: Console, Touch Output, Mouse Input, and External Touch Input.

**QM Setup**

To open the QM SETUP menu, press the **QM** button from the SETUP MENU. The QM SETUP menu offers controls for selecting *Peak* and *Boost* in *Video*, *S-Video* and *Component* modes.

After these parameters have been set, select the **Return** button to return to the SETUP MENU.

**QM SETUP**

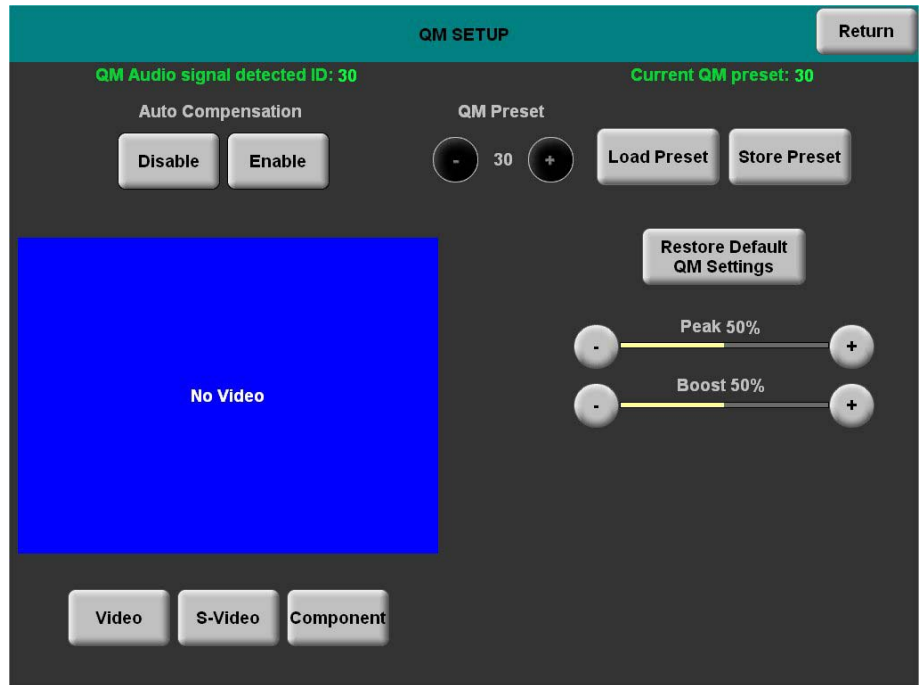

Refer to the following table for additional QM SETUP MENU details.

**QM Setup Details**

| <b>QM SETUP SCREEN CONTROL</b> | <b>DESCRIPTION</b>  |
|--------------------------------|---|
| Auto Compensation Disable      | Turns off auto compensation.  |
| Auto Compensation Enable       | Turns on auto compensation. When auto compensation is on, the QM receiving device uses the auto compensation data received from the QM transmitter.             |
| QM Preset                      | Displays the current QM Preset number. Saved presets can also be called up using this control. The - and + buttons decrement and increment the displayed value. |
| Load Preset                    | Will load the selected QM Preset.   |
| Store Preset                   | Will store any changes you have made to the QM setup at the displayed preset number.  |
| Restore Default QM Settings    | Restores the QM settings to their original defaults.  |

*(Continued on following page)*



*QM Setup Details (Continued)*

| QM SETUP SCREEN CONTROLS | DESCRIPTION   |
|--------------------------|---|
| Peak                     | Peak adjusts for high frequency attenuation that can occur over long cable lengths.                           |
| Boost                    | Boost compensates for overall signal loss that can occur over long cable lengths.                             |
| Video                    | Puts the menu in <i>Video</i> mode so that you can adjust the peak and boost signals for video.               |
| S-Video                  | Puts the menu in <i>S-Video</i> mode so that you can adjust the peak and boost signals for S-video.           |
| Component                | Puts the menu in <i>Component</i> mode so that you can adjust the peak and boost signals for component video. |

**General Audio Setup**

To open the GENERAL AUDIO SETUP menu press the **Audio** button from the SETUP MENU. The GENERAL AUDIO SETUP menu offers a series of buttons that adjust the volume level as indicated by the gauges. *Speaker Volume, Line Volume, Key Click Volume, WAV Volume* and *Headphone Volume* are independently adjustable. Controls for *Bass, Treble* and *Headphone Balance* are also provided

The **Play Test WAV File** button plays a short audio file. The **Restore Default Audio Settings** button returns all audio parameters to their default settings. Selection of the **QM Input** button from the GENERAL AUDIO SETUP menu displays the QM AUDIO INPUT SETUP menu. This menu allows adjustment of volume levels for QM audio inputs. After audio parameters have been set, select the **Return** button to return to the SETUP MENU.

**GENERAL AUDIO SETUP**

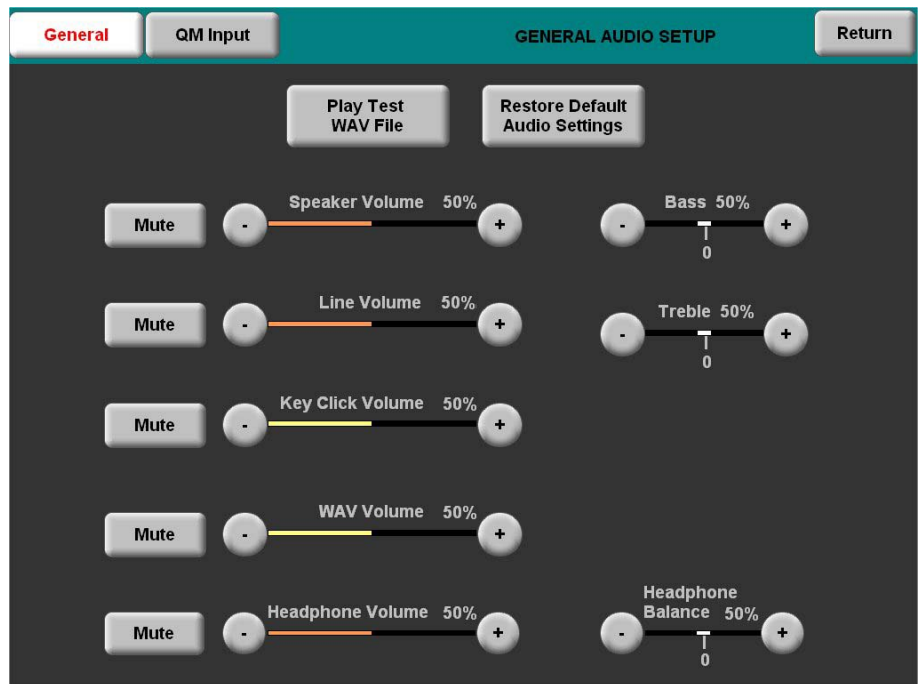

Refer to the following table for additional GENERAL AUDIO SETUP menu details.

*General Audio Setup Details*

| <b>GENERAL AUDIO SETUP SCREEN CONTROL</b> | <b>DESCRIPTION</b>  |
|---|---|
| Play Test WAV File                        | Plays a short WAV audio file.   |
| Restore Default Audio Settings            | Restores the audio settings to their factory defaults.  |
| Mute                                      | A separate <b>Mute</b> button is provided for each of the volume controls.  |
| Speaker Volume                            | The volume of all audio inputs (line, key click and WAV) is affected by the Speaker Volume control. If the Speaker Volume control is set to 100% the volume for any audio input is at maximum. If the Speaker Volume is set to 0% the value of all audio inputs is overridden and the touchpanel is silent. If the Speaker Volume is a percentage (say 50%), then all audio inputs can only achieve half their value. |
| Line Volume                               | Adjusts line level audio with the – and + buttons.  |
| Key Click Volume                          | Adjusts the level of the key click sound with the – and + buttons.  |
| WAV Volume                                | Adjusts the volume of the WAV file with the – and + buttons. Click <b>Play Test WAV File</b> button to sample and adjust the volume as a pre-loaded WAV file plays.   |
| Headphone Volume                          | Adjusts the level of the headphones with the – and + buttons. (This control is visible only when headphones are connected.)   |
| Bass                                      | Adjusts the overall bass output with the – and + buttons.   |
| Treble                                    | Adjusts the overall treble output with the – and + buttons.   |
| Headphone Balance                         | Adjusts the overall left/right balance of the headphone output with the – and + buttons. (This control is visible only when headphones are connected.)  |

*QM AUDIO INPUT SETUP*

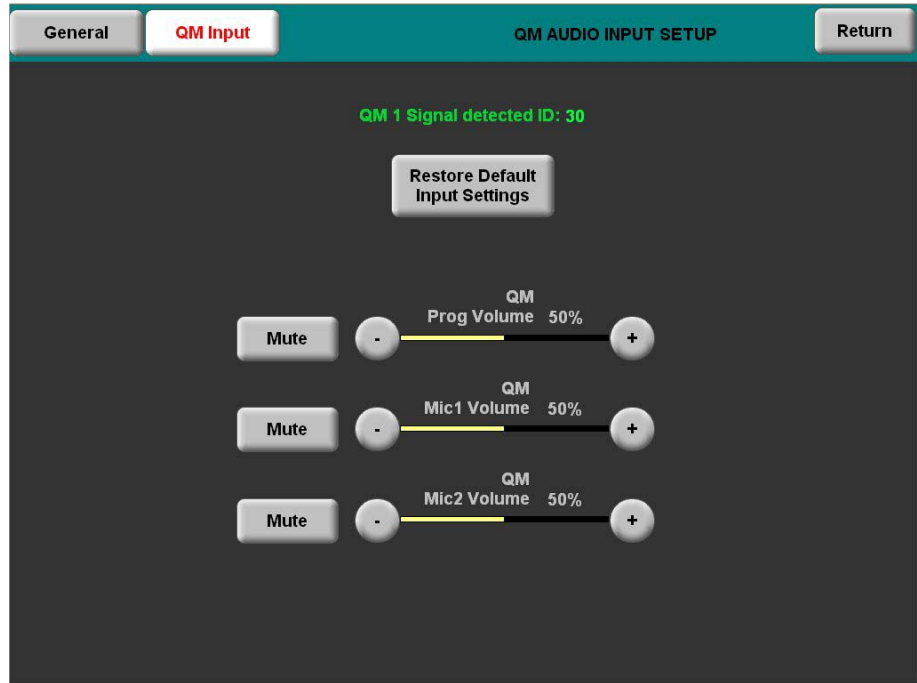

Refer to the following table for additional QM AUDIO INPUT SETUP menu details.

*QM Audio Input Setup Details*

| QM AUDIO INPUT SETUP SCREEN CONTROL | DESCRIPTION   |
|-------------------------------------|---|
| Restore Default Input Settings      | Returns audio settings to the factory defaults.                         |
| Mute                                | A separate <b>Mute</b> button is provided for each of the three inputs. |
| Prog Volume                         | Adjusts program audio with the – and + buttons.                         |
| Mic 1 Volume                        | Adjusts the level of microphone 1 with the – and + buttons.             |
| Mic 2 Volume                        | Adjusts the level of microphone 2 with the – and + buttons.             |

*Video Setup*

The touchpanel can display composite, S-video and component video input from one of the selected sources or from the QM input connector in both NTSC and PAL formats. Select the **Video** button from the SETUP MENU to display the first VIDEO SETUP menu, shown in the following illustration. You can select **Setup QM Video**, **Setup Video** or choose one particular input source.

A second VIDEO SETUP menu provides controls for *Video Preset* (+ and -), **Load Preset** and **Store Preset**. Controls for *Brightness*, *Contrast*, *Saturation* and *Hue* are provided independently for each video source.

The **Restore Default Color Settings** button resets the controls to the factory settings. After video parameters have been set, select the **Return** button to return to the SETUP MENU.

Refer to the following graphics and tables for additional information.

**VIDEO SETUP**

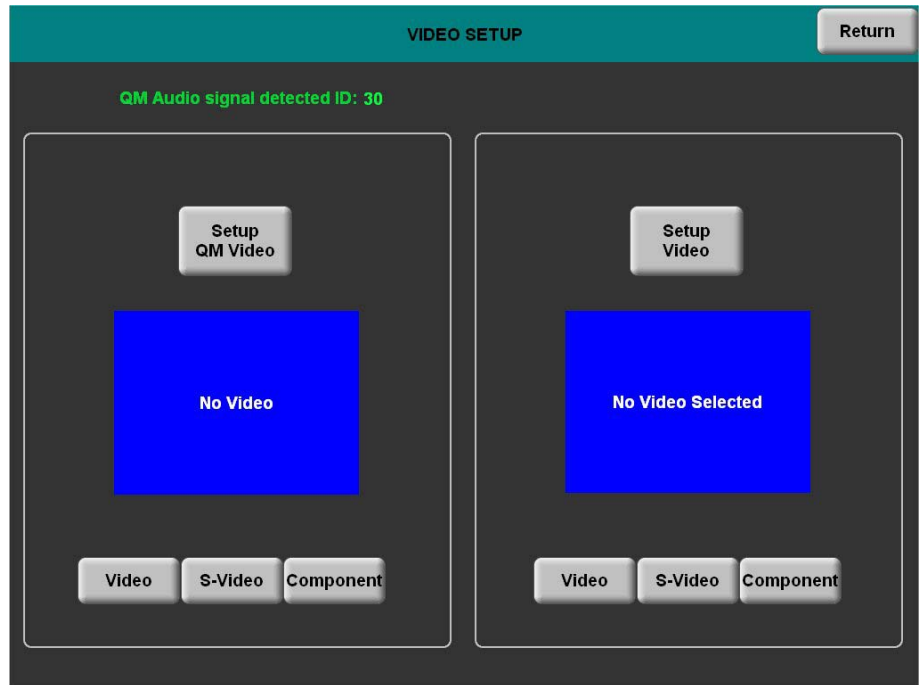

*Video Setup Details*

| VIDEO SETUP SCREEN CONTROL | DESCRIPTION  |
|----------------------------|--|
| Setup QM Video             | Displays the VIDEO SETUP menu. By default, the VIDEO SETUP menu displays video controls: Brightness, Contrast, Saturation and Hue on the right side of the menu. |
| Video                      | Pressing this before pressing the <b>Setup QM Video</b> button will open the VIDEO SETUP menu in <i>Video</i> mode.  |
| S-Video                    | Pressing this before pressing the <b>Setup QM Video</b> button will open the VIDEO SETUP menu in <i>S-Video</i> mode.  |
| Component                  | Pressing this before pressing the <b>Setup QM Video</b> button will open the VIDEO SETUP menu in <i>Component</i> mode.  |
| Setup Video                | Displays the VIDEO SETUP menu. By default, the VIDEO SETUP menu displays video controls: Brightness, Contrast, Saturation and Hue on the right side of the menu. |
| Video                      | Pressing this before pressing the <b>Setup Video</b> button will open the VIDEO SETUP menu in <i>Video</i> mode.   |
| S-Video                    | Pressing this before pressing the <b>Setup Video</b> button will open the VIDEO SETUP menu in <i>S-Video</i> mode.   |
| Component                  | Pressing this before pressing the <b>Setup Video</b> button will open the VIDEO SETUP menu in <i>Component</i> mode.   |

*VIDEO SETUP (Second Screen)*

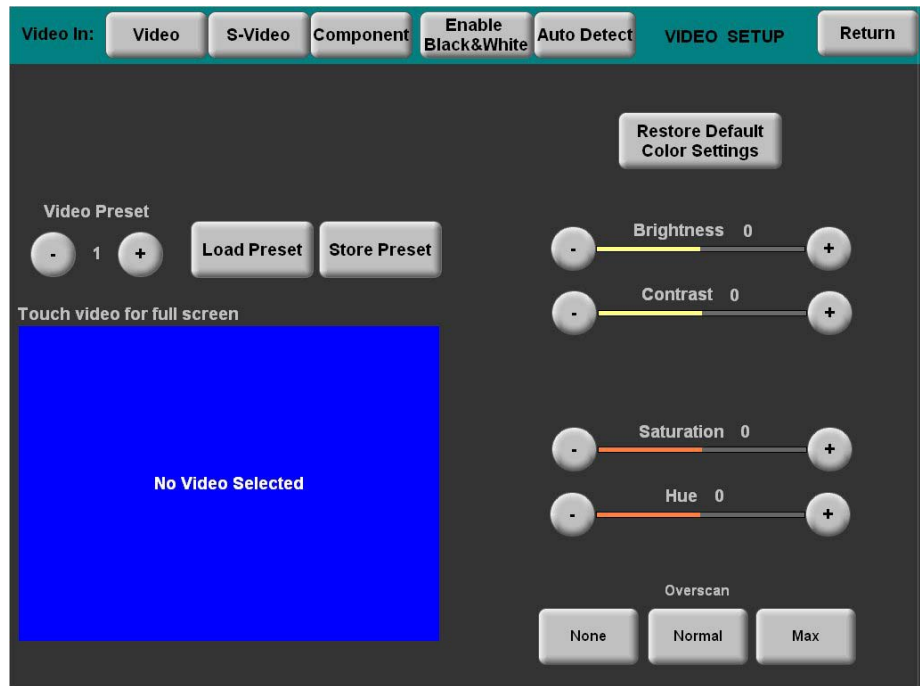

*Video Setup Details – Video, S-Video and Component*

| VIDEO SETUP SCREEN CONTROL   | DESCRIPTION  |
|------------------------------|--|
| Video                        | Selects composite video source at <i>Video In</i> .  |
| S-Video                      | Selects S-video at <i>Video In</i> .   |
| Component                    | Selects Component video at <i>Video In</i> .   |
| Enable Black & White         | Enables display of black & white input signal.   |
| Auto Detect                  | Enabling the auto-detect mode automatically selects video source connected to the <i>Video In</i> input.   |
| Return                       | Reverts to the previous menu.  |
| Video Preset                 | Displays the current video preset number. Saved presets can also be called up using this control. The – and + buttons decrement and increment the displayed value. |
| Load Preset                  | Will load the selected video preset.   |
| Store Preset                 | Will store any changes you have made to the video setup at the displayed preset number.  |
| Restore Default Color Values | Restores the video settings to their original defaults.  |
| Brightness <sup>1,2</sup>    | Adjusts video image brightness with the – and + buttons.   |
| Contrast <sup>1,2</sup>      | Adjusts video image contrast with the – and + buttons.   |
| Saturation <sup>1,2</sup>    | Adjusts video image saturation with the – and + buttons.   |
| Hue <sup>1,2,3</sup>         | Adjusts video image hue with the – and + buttons.  |

*(Continued on following page)*

*Video Setup Details – Video, S-Video and Component (Continued)*

| VIDEO SETUP<br>SCREEN<br>CONTROL                     | DESCRIPTION  |
|--|--|
| <p>Overscan</p> <p>None</p> <p>Normal</p> <p>Max</p> | <p>These controls adjust the amount of video information at the edges of the image. This part of the video picture is usually beyond the display capabilities of the screen.</p> <p>Sets the video screen so there is no overscan. The amount of used screen area is smallest in this configuration.</p> <p>Sets the video screen for normal overscan. This results in more area of the screen being used.</p> <p>This sets the video screen area to the maximum. The screen area is largest in this configuration. All video information at the edges is visible.</p> |

1. Video default is zero (0) for each of the video parameters (brightness, contrast, saturation and hue).
2. Adjustment applies to the currently selected video source only.
3. Hue is not available with component video.

**Diagnostics Menu**

The **Diagnostics** button from the MAIN MENU contains controls for diagnostic tools. The diagnostic tools should only be used under supervision from a Crestron customer service representative during telephone support. The options available from the DIAGNOSTICS MENU are numeric in nature and their interpretation is beyond the scope of this manual.

**DIAGNOSTICS MENU**

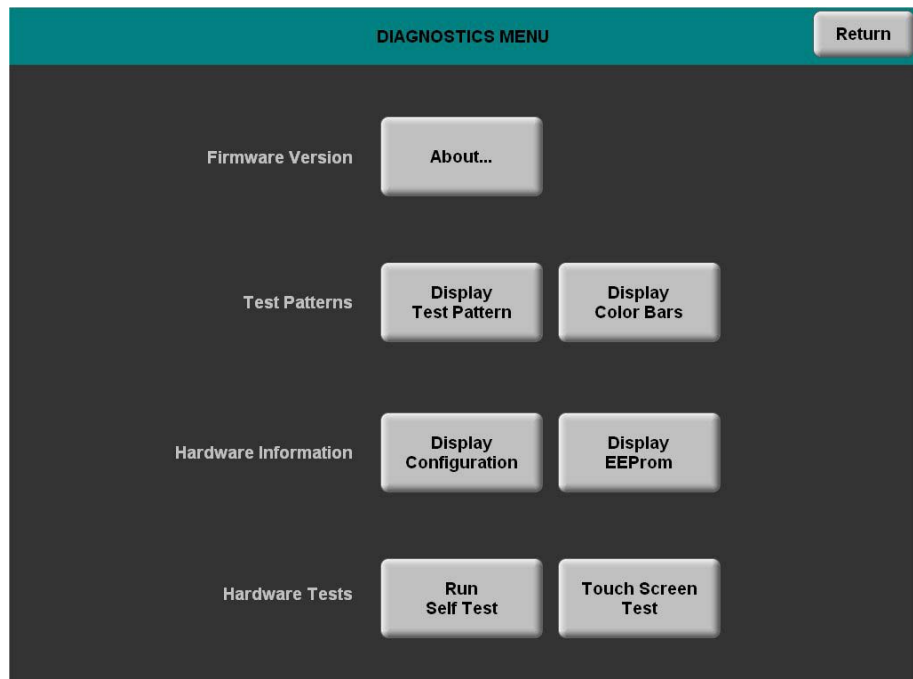

## Hardware Hookup

### Ventilation

The TPS-12B/W, TPS-15B/W & TPS-17B/W should be used in a well-ventilated area. The venting holes should not be obstructed under any circumstances. If the TPS-12B/W, TPS-15B/W & TPS-17B/W is hot to the touch, consider using forced air ventilation.

To prevent overheating, do not operate this product in an area that exceeds the environmental temperature range listed in the table of specifications.

### Connect the Device

Make the necessary connections as called out in the illustration that follows this paragraph. Refer to “Network Wiring” on page 17 before attaching the 4-position terminal block connector. Apply power after all connections have been made.

---

**CAUTION:** Do not apply excessive pressure to the touchscreen display during handling. Doing so can crack the screen and damage the touchpanel.

**NOTE:** The maximum continuous current from equipment under any external load conditions shall not exceed a current limit that is suitable for the minimum wire gauge used in interconnecting cables. The ratings on the connecting unit's supply input should be considered to prevent overloading the wiring.

**NOTE:** The headphone output is for WAV and Line audio only. It does not carry the microphone signal. Use the AUDIO OUT on the TPMC-CH-IMC for the microphone signal.

**NOTE:** TPS-12B/W, TPS-15B/W & TPS-17B/W touchpanels include a TPMC-CH-IMC Interface Module for system connection. The TPMC-CH-IMC serves as an interface between the touchpanel, external A/V system, microphone output and the Cresnet system. Refer to the TPMC-CH-IMC Operations Guide (Doc. 6345) for hardware hookup using this interface.

**NOTE:** For CAT5 and QuickMedia connections, use Crestron Certified Wire.

**NOTE:** Crestron recommends an independent power supply for the touchpanel.

---

Refer to the diagram on the following page for access to the connectors and cable routing.

*Access to I/O Panel and Cable Routing*

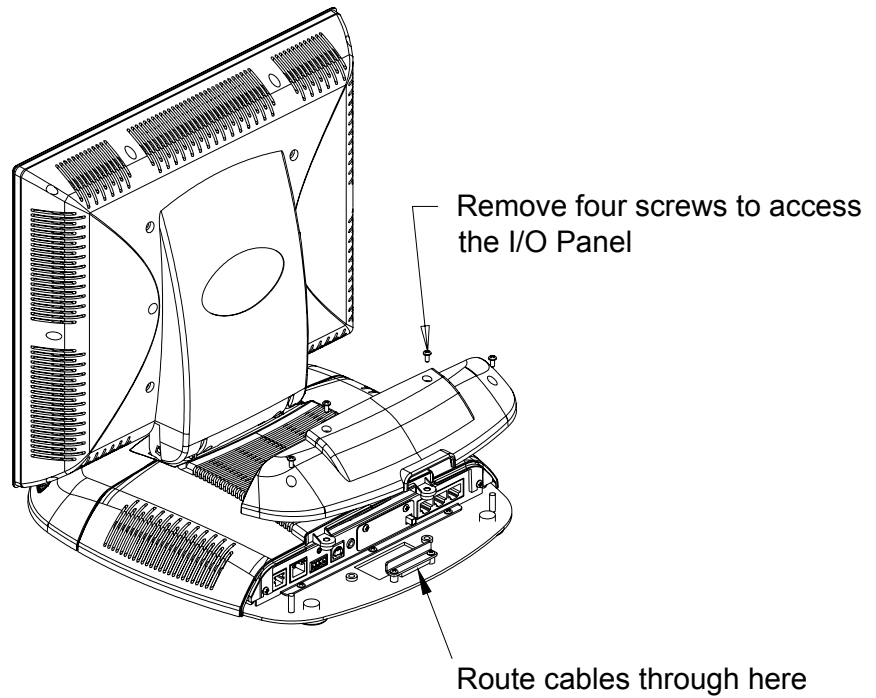

The TPS-12B/W, TPS-15B/W & TPS-17B/W touchpanels have rubber pads on the underside of the base so they can rest on a horizontal surface. Make the required connections as shown and described in the following sections. Refer to the illustration on the following page for proper connections; apply power last.

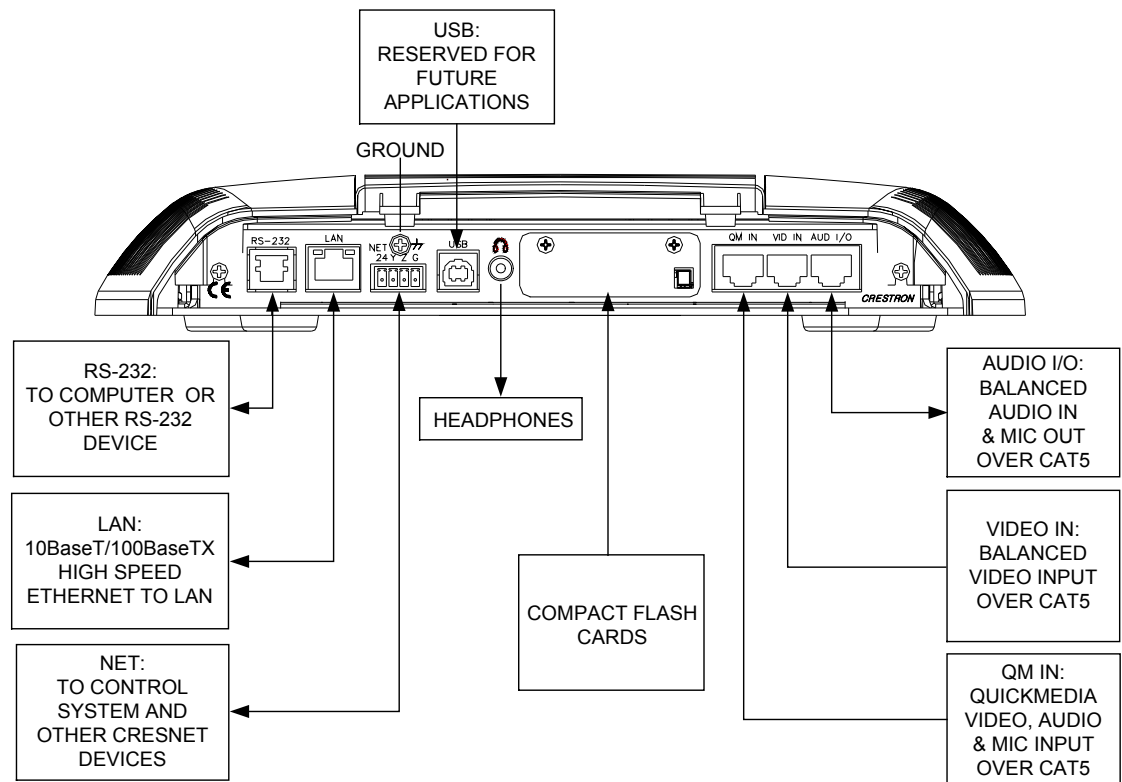

*Hardware Connections for the TPS-12B/W, TPS-15B/W & TPS-17B/W*

**CAUTION:** Only use the TPMC-CH-IMC Interface Module when connecting to the VIDEO IN port. Use of older “IMC” products, such as those with a 10-pin RJ-45 based interface, could damage the panel.

**NOTE:** A QuickMedia transmitter such as the QM-TX is required in order to connect conventional video and audio sources to the QM IN port. The QM port is not connected through any “IMC” interface.

**NOTE:** The connectors are not accessible after the rear cover is reinstalled.

### **TPMC-CH-IMC Interface Module**

For networks without CAT5 audio and video, the TPMC-CH-IMC (as well as a 15-foot triamese interface cable) is included to convert unbalanced video sent over coax cable and balanced/unbalanced audio sent over shielded, twisted-pair wiring to Crestron Certified Wiring for connection to the touchpanels.

**NOTE:** The TPMC-CH-IMC is not for use with QuickMedia.

**NOTE:** Audio and video wiring between the touchpanel and module may be up to 500 feet for component video or 750 feet for composite and S-Video. However, the length of Cresnet cable must account for limits based upon the touchpanel power requirements. Refer to the latest version of the TPMC-CH-IMC Interface Module Operations Guide (Doc. 6345) and “Network Wiring” on page 17.

### **QM-TX QuickMedia Transmitter**

The QM-TX QuickMedia Transmitter can be used to connect a video or audio source to a QuickMedia network without a locally available QM transmitter (such as the QM-WMC).

The QM-TX accepts composite video, S-video, component video and audio signals. These signals are encoded and converted to the QuickMedia standard and fed over a CAT5E or CAT6 cable to a QM receiver (such as the TPS-12B/W, TPS-15B/W & TPS-17B/W). All signal routing occurs automatically under the command of the control system.

For more information, refer to the latest version of the QM-TX Operations Guide (Doc. 6334).

### **Tilt Angle Tension Adjustment**

Use a 5/32 inch socket (not included) with a hex drive key (Allen wrench) to increase or decrease pivot tension at the base of the touchscreen. Turning the key clockwise increases tension, counterclockwise decreases tension.

#### ***Tension Adjustment Screw***

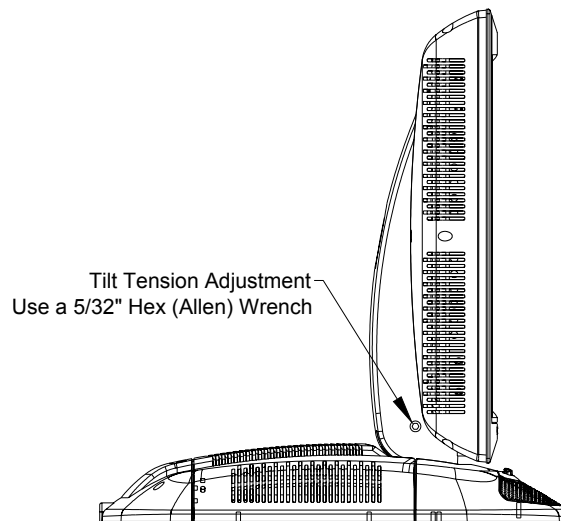

### **Recommended Cleaning**

Keep the surface of the touchscreen free of dirt, dust or other materials that could degrade optical properties. Long-term contact with abrasive materials can scratch the surface, which may detrimentally affect image quality.

For best cleaning results use a clean, damp, non-abrasive cloth with any commercially available non-ammonia glass cleaner. Bezels may not provide a complete watertight seal. Therefore, apply cleaning solution to the cloth rather than the surface of the touchscreen. Wipe touchscreen clean and avoid getting moisture beneath the bezels.

---

## Programming Software

---

### Have a question or comment about Crestron software?

Answers to frequently asked questions (FAQs) can be viewed in the Online Help section of the Crestron website. To post a question or view questions you have submitted to Crestron's True Blue Support, log in at <http://support.crestron.com>. First-time users will need to establish a user account.

---

### Earliest Version Software Requirements for the PC

---

**NOTE:** Crestron recommends that you use the latest software to take advantage of the most recently released features. The latest software is available from the Crestron website.

---

Crestron has developed an assortment of Windows®-based software tools to develop a Cresnet system. The following are the minimum recommended software versions for the PC:

#### *Software*

| TASK  | REQUIRED SOFTWARE VERSION  |
|---|--|
| Program control system to operate TPS-12B/W, TPS-15B/W & TPS-17B/W.   | SIMPL Windows version 2.06.16 or later with Library update 342 or later. Also requires Crestron Database version 17.2.0 or later.  |
| Upload program and firmware.  | Crestron Toolbox version 1.0 or later.   |
| For graphical touchscreen design.   | Crestron VisionTools® Pro-e version 3.4.0.7 or later.  |
| Program with simple wizards for QuickMedia systems using a TPS-12B/W, TPS-15B/W & TPS-17B/W (optional but recommended). | Crestron SystemBuilder™ version 2.0 or later (requires SIMPL Windows, VT Pro-e, Crestron Database and Crestron Engraver). Refer to software release notes or Crestron website for other required Crestron software packages. |

### Programming with Crestron SystemBuilder

Crestron SystemBuilder is the easiest method of programming but does not offer as much flexibility as SIMPL Windows. For additional details, download SystemBuilder from the Crestron website and examine the extensive help file.

### Programming with SIMPL Windows

---

**NOTE:** While SIMPL Windows can be used to program the TPS-12B/W, TPS-15B/W & TPS-17B/W, it is recommended to use SystemBuilder for configuring and tuning a QuickMedia system.

---

SIMPL Windows is Crestron's premier software for programming Crestron control systems. It is organized into two separate but equally important "Managers".

**Configuration Manager**

Configuration Manager is the view where programmers “build” a Crestron control system by selecting hardware from the *Device Library*.

- To incorporate the TPS-12B/W, TPS-15B/W & TPS-17B/W (Cresnet) into the system, drag the TPS-12B/W, TPS-15B/W & TPS-17B/W from the Touchpanels | Touchpanels (Cresnet) folder of the *Device Library* and drop it in the *System Views*.

**Locating the TPS-12B/W, TPS-15B/W & TPS-17B/W (Cresnet) in the Device Library**

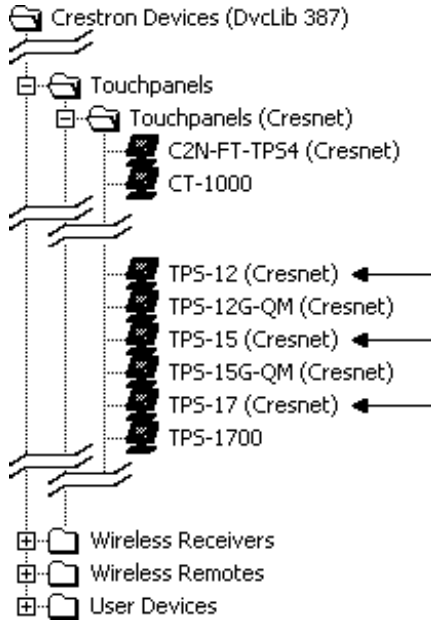

- To incorporate the TPS-12B/W, TPS-15B/W & TPS-17B/W (Ethernet) into the system, drag the TPS-12B/W, TPS-15B/W & TPS-17B/W from the Touchpanels | Touchpanels (Ethernet) folder of the *Device Library* and drop it in the *System Views*.

*Locating the TPS-12B/W, TPS-15B/W & TPS-17B/W (Ethernet) in the Device Library*

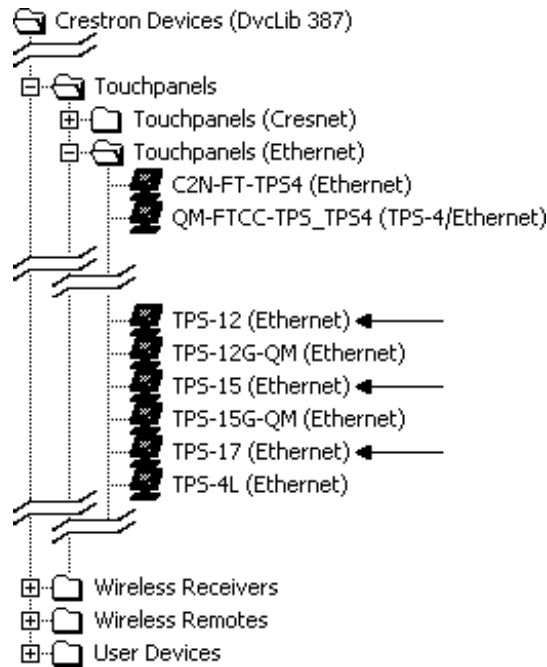

- The system tree of the control system displays the device in the appropriate slot with a default Net ID or IP ID as shown in the following illustration.

**NOTE:** Observe that there is both an Ethernet device in Slot 8 and a Cresnet device in Slot 9 of the following illustration. It is possible to have both types of device attached to a control system so long as the control system has either a built-in or expansion Ethernet interface.

*C2Net Device, Slot 8 and 9*

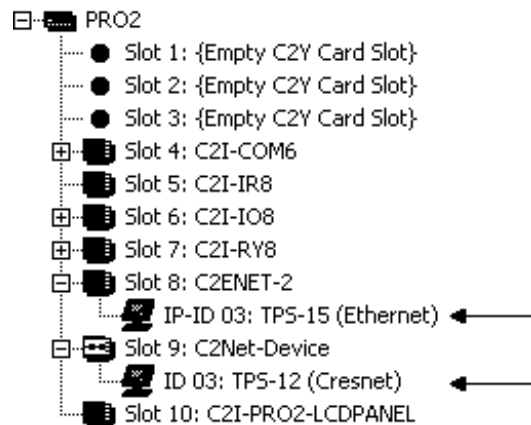

- Additional TPS-12B/W, TPS-15B/W & TPS-17B/W devices are assigned different Net ID (for Cresnet devices ) or IP ID (for Ethernet devices) numbers as they are added.
- If necessary, double click a device to open the “Device Settings” window and change the Net ID or IP ID, as shown in the following figures.

*“TPS-12B/W (Cresnet) Device Settings” Window  
(Same as window for TPS-15B/W and TPS-17B/W)*

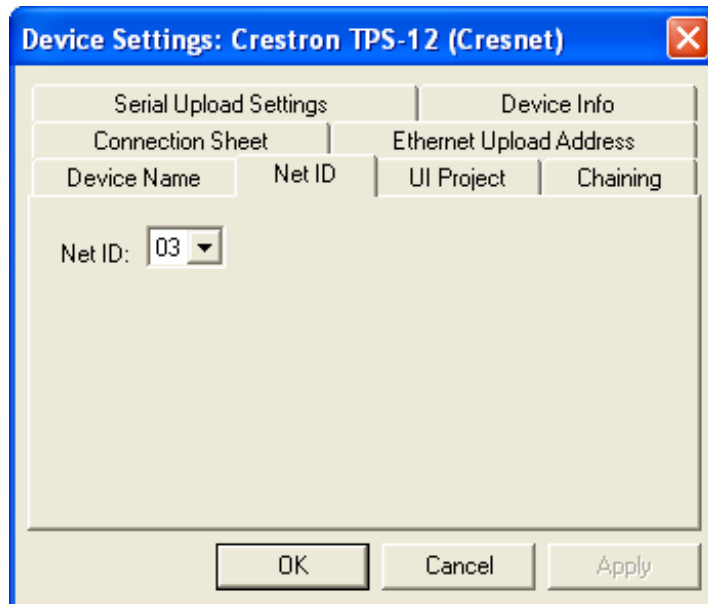

*“TPS-15B/W (Ethernet) Device Settings” Window  
(Same as window for TPS-12B/W and TPS-17B/W)*

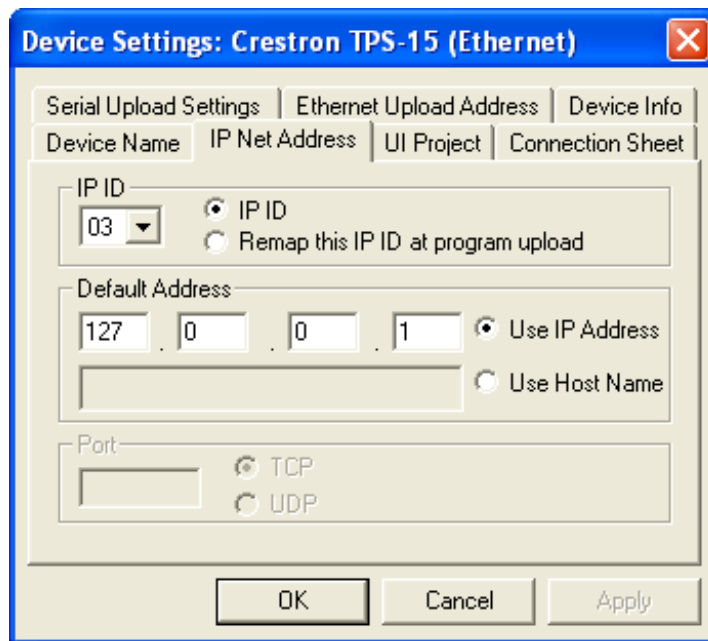

- The ID code specified in the SIMPL Windows program must match the Net ID or IP ID of each unit.

**Program Manager**

Program Manager is the view where programmers “program” a Crestron control system by assigning signals to symbols. The symbol can be viewed by double clicking on the icon or dragging it into *Detail View*. Each signal in the symbol is described in the SIMPL Windows help file (F1).

## Programming with VisionTools Pro-e

Touchpanel screens should be created in VisionTools Pro-e to allow switching of source signals to desired outputs as well as selection of the system mode. There are no special programming requirements to use the functions of the TPS-12B/W, TPS-15B/W & TPS-17B/W in a room-control system.

### Multi-Mode Objects

*Multi-mode objects offer high-performance programming!*

The single most-advanced VT Pro-e high-performance programming technique involving the TPS-12B/W, TPS-15B/W & TPS-17B/W is the concept of multi-mode objects. A multi-mode object (i.e. button, legend, etc.) is an object drawn on a VT Pro-e page that can have one or more active and inactive visible settings (*modes*).

For examples, refer to <http://www.crestron.com/exampleprograms> and search for multi-mode object examples. This file contains the VT Pro-e touchpanel files and SIMPL Windows files that illustrate the high-performance capabilities of multi-mode objects.

### WAV File Audio Messages

The TPS-12B/W, TPS-15B/W & TPS-17B/W touchpanels are capable of playing audio messages as system prompts and responses. These files are recorded as WAV files on a PC using an audio utility such as Sound Recorder that is packaged with Microsoft Windows 95/98/Me/XP/NT/ 2000™. Files from other sources may also be converted to an acceptable format by using this or a similar utility. Many other audio utilities are available commercially or as shareware. The TPS-12B/W, TPS-15B/W & TPS-17B/W touchpanels only accept the following WAV file format: **PCM, 8KHz, mono, 8-bit**. For more information about how to use Sound Recorder, refer to its User's Guide and extensive help information provided with the software. Also refer to the help file in VT Pro-e to learn how to use its audio tool, Sound Manager, to attach WAV files to a touchpanel project.

Pre-recorded WAV files for voice prompts and responses are available from Crestron. These files can be stored into and programmed for use in the touchpanel directly or may be edited with the Sound Recorder. For example, the individual files can be combined to create custom messages.

---

**NOTE:** Touchpanel WAV files can be obtained from the Wave LC Library of the Crestron FTP site.

---

### Bit Depth and File Size

A bit depth refers to the number of memory bits used to store color data for each pixel in a raster image. A touchpanel raster image consists of a rectangular grid of picture elements (pixels). Each pixel uses the same amount of memory to store its color data. The amount of memory is called the bit depth of the image.

Greater bit depths are required to represent finer gradations of color. Increasing bit depth necessarily increases file size. A black and white drawing requires only one bit per pixel to store all the available color information. Using a 32-bit per pixel bit depth for a black and white image increases the file size 32 times without adding anything to the black and white image quality.

In an 8-bit per pixel system, the associated 8-bits of video memory for every screen pixel contain a value referring to a location in an 8-bit color table. In this way any one of the specific 256 color table locations is assigned to a pixel.

A 16-bit highcolor system is considered sufficient to provide life-like colors. It is encoded using 5-bits to represent red, 5-bits to represent blue and (since the human

eye is more sensitive to the color green) 6-bits to represent 64 levels of green. These can therefore be combined to provide 65,536 mixed colors ( $32 \times 32 \times 64 = 65,536$ ).

In a 24-bit graphics display, the video memory allocates 24 bits for each pixel on the screen enabling each pixel to take on any one of a possible 16.7 million colors. Each 24-bit value is composed of 8-bits for red, 8-bits for green and 8-bits for blue. These triplets of 8-bit values are also referred to as the red, green and blue color planes. A 24-bit image is actually composed of three component images which combine to create the truecolor picture. The reason this is called truecolor is that this is near the maximum number of colors the human eye is able to detect.

Truecolor images are sometimes represented by a 32-bit value. The extra 8-bits do not enhance the precision of the color representation but act as an alpha channel that represents pixel translucence. The 32-bit truecolor has become popular on the computer desktop to provide effects such as translucent windows, fading menus and shadows.

In graphics intensive applications such as touchpanels, raising or lowering the color depth of the displayed graphics can achieve a balance of performance and quality. Lower color depths do not require as much frame buffer memory or display bandwidth, allowing them to be generated and displayed more quickly. Increasing color depth results in higher color quality at the expense of display speed and responsiveness. By using mostly 8-bit or 16-bit graphics and holding the 32-bit graphics to a minimum (e.g. for a family photo, etc.), you can create a sophisticated project that will fit in the memory space provided and have the touchpanel remain very responsive.

#### *Relationship of Bits to Colors*

| NUMBER OF BITS | NUMBER OF COLORS                      |
|----------------|---------------------------------------|
| 1 bit          | Black and White                       |
| 2 bits         | 4 Colors                              |
| 4 bits         | 16 Colors                             |
| 8 bits         | 256 Colors                            |
| 16 bits        | 65,536 Colors (Highcolor)             |
| 24 bits        | 16.7 million Colors (Truecolor)       |
| 32 bits        | 16.7 million Colors plus Transparency |

When creating a VT Pro-e project you can elect to compress and reduce the image size in the “Page Properties” window for the entire page and/or perform the same function of reducing the image size using the “Image Properties” window. A reduction in image size will save a considerable amount of memory space for your project.

In VT Pro-e, the **Compress** checkbox permits the image to be compressed when compiling. The **16 Bits** checkbox converts a 24-bit or 32-bit image to 16 bits. This conversion to a 16-bit image may cause the loss of some subtle shading. To compensate for this, use the dithering to simulate the original shading. Various dithering types are available. Refer to the following illustrations.



*VT Pro-e “Page Properties” Window – Bit Depth Selection*

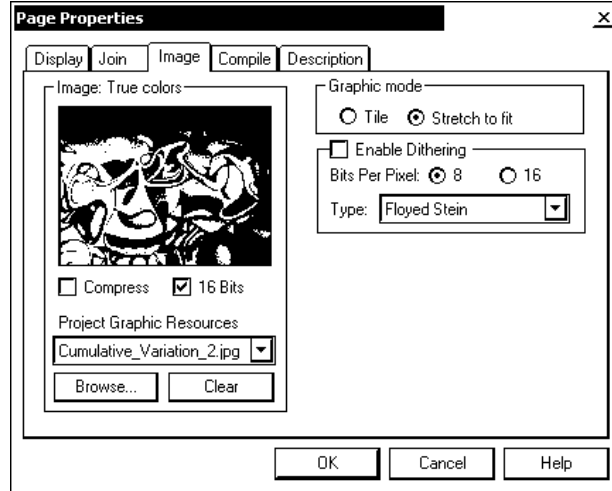

*VT Pro-e “Image Properties” Window – Bit Depth Selection*

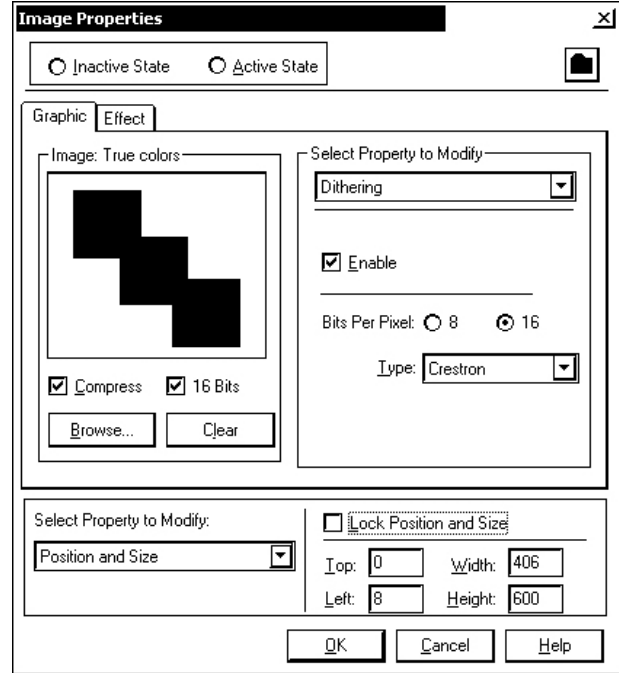

### **Hard Button Programming**

Four of the buttons can be programmed to access any frequently used command. Each button has a permanently fixed digital join number. The sequence of digital join numbers is (left to right) 1 through 4. Refer to the following diagram for their assigned join numbers. A description for each button signal is described in the SIMPL Windows help file (F1).

*Pushbutton Layout and Join Number Assignment*

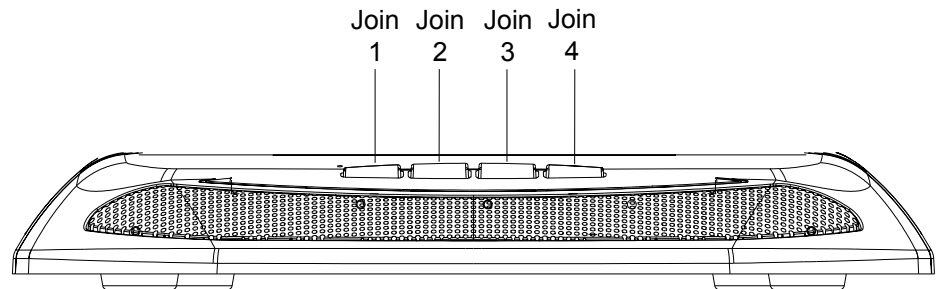

### **MultiByte International Characters**

Most languages use a single byte of eight bits to represent a character, e.g. English, French, German, Hebrew, Russian, Thai, etc.

Multibyte character fonts require more than the usual eight bits to specify a character. This occurs when a language has more than 256 characters ( $2^8$ ) in a font. For example, Chinese fonts contain several thousand characters. Other multibyte languages include Japanese and Korean.

There are two separate applications with multibyte characters – static text on buttons and indirect text on buttons. No Isys touchpanel firmware changes are required in either case.

Indirect text on a button is entered in VT Pro-e and the actual string to be displayed is entered in SIMPL Windows. As of this publication date only completely single byte or completely multibyte strings may be entered or they will not be compiled correctly in SIMPL Windows. In other words, you cannot enter Chinese characters interspersed with numbers. You can enter Chinese characters or numbers in separate strings or you can pad each number with “\x00” to make it multibyte and then combine it with Chinese characters in the same string.

Of course you can always use the workaround of showing a graphic that displays the string but it is not dynamic. To compile and use multibyte characters it is essential that the operating system understand the language. Windows XP is available in many international languages and add-on software is available for other versions of Windows.

## **Example Program**

An example program for the TPS-12B/W, TPS-15B/W & TPS-17B/W is available from the Crestron website (<http://www.crestron.com/exampleprograms>).

## Uploading and Upgrading

Crestron recommends using the latest programming software and that each device contains the latest firmware to take advantage of the most recently released features. However, before attempting to upload or upgrade it is necessary to establish communication. Once communication has been established, files (for example, programs, projects or firmware) can be transferred to the control system (and/or device). Finally, program checks can be performed (such as changing the device ID or creating an IP table) to ensure proper functioning.

### Establishing Communication

Use Crestron Toolbox for communicating with the TPS-12B/W, TPS-15B/W & TPS-17B/W; refer to the Crestron Toolbox help file for details. There are three methods of communication.

#### Direct Serial Communication

**NOTE:** Required for initial setup of Ethernet parameters.

##### Direct Serial Communication

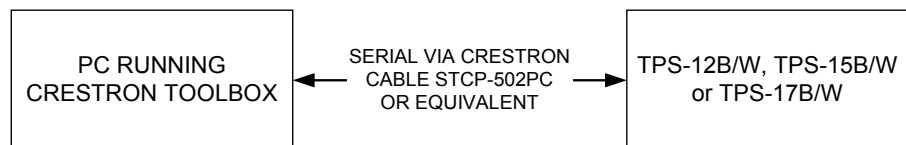

- The **RS-232** port on the TPS-12B/W, TPS-15B/W & TPS-17B/W connects to the serial port on the PC via a serial cable (Crestron STCP-502PC or equivalent).
- Use the Address Book in Crestron Toolbox to create an entry using the expected serial communication protocol (RS-232, auto-detect baud rate, no parity, 8 data bits, 1 stop bit, XON/XOFF disabled, RTS/CTS disabled).
- Display the TPS-12B/W, TPS-15B/W or TPS-17B/W's "System Info" window (click the  icon); communications are confirmed when the device information is displayed.

#### Indirect Serial Communication

##### Indirect Serial Communication

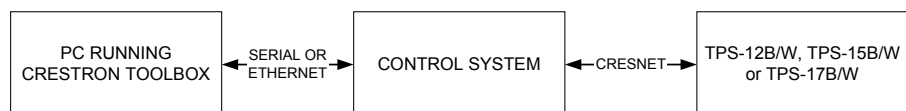

- TPS-12B/W, TPS-15B/W or TPS-17B/W connects to control system via Cresnet.
- Establish communications between the PC and the control system as described in the latest version of the 2-Series Control Systems Reference Guide (Doc. 6256).

**TCP/IP Communication**

**NOTE:** Required for operation with a Crestron control system.

**Ethernet Communication**



- Establish serial communication between TPS-12B/W, TPS-15B/W or TPS-17B/W and PC.
- Enter the IP address, IP mask and default router of the TPS-12B/W, TPS-15B/W or TPS-17B/W via the Crestron Toolbox (**Functions | Ethernet Addressing**); otherwise enable DHCP.
- Confirm Ethernet connections between TPS-12B/W, TPS-15B/W or TPS-17B/W and PC. If connecting through a hub or router, use CAT5 straight through cables with 8-pin RJ-45 connectors. Alternatively, use a CAT5 crossover cable to connect the two LAN ports directly without using a hub or router.
- Use the Address Book in the Crestron Toolbox to create an entry for the TPS-12B/W, TPS-15B/W or TPS-17B/W with the TPS-12B/W, TPS-15B/W or TPS-17B/W’s TCP/IP communication parameters.
- Display the “System Info” window (click the  icon) and select the TPS-12B/W, TPS-15B/W or TPS-17B/W entry.

**Programs, Projects and Firmware**

Program, project or firmware files may be distributed from programmers to installers or from Crestron to dealers. Firmware upgrades are available from the Crestron website as new features are developed after product releases. One has the option to upload programs and projects via the programming software or to upload and upgrade via the Crestron Toolbox. For details on uploading and upgrading, refer to the SIMPL Windows help file, VisionTools Pro-e help file, or the Crestron Toolbox help file.

**SIMPL Windows**

If a SIMPL Windows program is provided, it can be uploaded to the control system using Simple Windows or Crestron Toolbox.

**VisionTools Pro-e**

Upload the VisionTools Pro-e file to the touchpanel using VisionTools Pro-e or Crestron Toolbox. If loading a project to a touchpanel that has an external compact flash slot, please use Crestron Toolbox.

**Firmware**

Check the Crestron website to find the latest firmware. (New users may be required to register to obtain access to certain areas of the site, including the FTP site.)

- Upgrade TPS-12B/W, TPS-15B/W & TPS-17B/W firmware via Crestron Toolbox.
- Establish serial or TCP/IP communications with the TPS-12B/W, TPS-15B/W & TPS-17B/W and display the “System Info” window.

- Select **Functions | Firmware...** to upgrade the TPS-12B/W, TPS-15B/W & TPS-17B/W firmware.

## Program Checks

Actions that can be performed on the TPS-12B/W, TPS-15B/W & TPS-17B/W vary depending on whether it is connected via Cresnet or Ethernet.

### *Cresnet Connections*

For Cresnet connections, display the network device tree (**Tools | Network Device Tree**) to show all network devices connected to the control system. Right-click on the TPS-12B/W, TPS-15B/W or TPS-17B/W L to display actions that can be performed on the TPS-12B/W, TPS-15B/W & TPS-17B/W.

### *Ethernet Connections*

For Ethernet connections, display the “System Info window (click the  icon) and select the **Functions** menu to display actions that can be performed on the TPS-12B/W, TPS-15B/W & TPS-17B/W.

Be sure to use the Crestron Toolbox to create the TPS-12B/W, TPS-15B/W or TPS-17B/W IP table.

- Select **Functions | IP Table Setup**.
- Add, modify or delete entries in the IP table. The TPS-12B/W, TPS-15B/W or TPS-17B/W can have only one IP table entry.
- A defined IP table can be saved to a file or sent to the device.

Edit the control system’s IP table to include an entry for the TPS-12B/W, TPS-15B/W or TPS-17B/W. The entry should list the TPS-12B/W, TPS-15B/W or TPS-17B/W’s IP ID (specified on TPS-12B/W, TPS-15B/W or TPS-17B/W’s IP table) and the internal gateway IP address 127.0.0.1.

## Problem Solving

### Troubleshooting

The following table provides corrective action for possible trouble situations. If further assistance is required, please contact a Crestron customer service representative.

#### *TPS-12B/W, TPS-15B/W & TPS-17B/W Troubleshooting*

| <b>TROUBLE</b>                                      | <b>POSSIBLE CAUSE(S)</b>   | <b>CORRECTIVE ACTION</b>   |
|---|--|--|
| TPS-12B/W, TPS-15B/W & TPS-17B/W does not function. | TPS-12B/W, TPS-15B/W & TPS-17B/W is not receiving power.                   | Verify power to unit. Use only Crestron power supplies for Crestron equipment.   |
|   | Incorrect cable connections.   | Follow connection procedures in this guide and inspect connector pins.   |
|   | Incorrect firmware/software.   | Update firmware/software versions as per those listed in the "Specifications" section.   |
|   | Touchpanel is incorrectly calibrated.                                      | Enter "SETUP MODE" and recalibrate.  |
|   | Touchpanel is not communicating with the network.                          | Use Toolbox to poll the network. Verify network connection to the touchpanel.  |
|   | Brightness is set too low.   | Adjust touchpanel brightness. Refer to "Setup Menu" on page 22.  |
| Touchpanel is not responding.                       | Incorrect network wiring.  | Touch the screen to remove the message and verify correct wiring to all connectors.  |
|   | Touchpanel Cresnet ID is not set to match the Net ID in the SIMPL program. | Use Crestron Toolbox to poll the network. Verify the Cresnet ID for the touchpanel is properly set to match the Net ID in the SIMPL program. |
|   | Touchpanel Cresnet ID is not unique; two or more units share the same ID.  | Use Crestron Toolbox to poll the network and verify that each ID is used only once.  |
|   | ICMP is disabled.  | Enable ICMP by typing <b>ICMP ON</b> at the command prompt in the Toolbox Text Console.  |
| No video displayed.                                 | Wrong VT Pro-e or SIMPL Windows programs.                                  | Verify correct programs. Verify proper video set up.   |
|   | Incorrect input connection.  | Verify video input and QM connections.   |

*(Continued on following page)*

*TPS-12B/W, TPS-15B/W & TPS-17B/W Troubleshooting (Continued)*

| TROUBLE  | POSSIBLE CAUSE(S)   | CORRECTIVE ACTION   |
|--|---|---|
| TPS-12B/W, TPS-15B/W & TPS-17B/W does not respond to ping command. | IP address not correct (LAN green and amber LEDs are off).              | Assign correct IP address to TPS-12B/W, TPS-15B/W & TPS-17B/W.                      |
|  | IP mask not correct (LAN green and amber LEDs are on).                  | Assign correct IP mask.   |
|  | The PC and the TPS-12B/W, TPS-15B/W & TPS-17B/W are not on same subnet. | Ensure that the PC and the TPS-12B/W, TPS-15B/W & TPS-17B/W are on the same subnet. |
| Mouse or touchpanel does not work.                                 | Incorrect Touch settings.   | Check Touch settings on INTERFACE MENU.   |
| Touchpanel does not communicate with RS-232 devices.               | Incorrect RS-232 settings.  | Match communication settings of touchpanel to peripheral device.                    |
| Touchpanel display is dark.  | Standby timeout has elapsed.  | Touch the screen to reactivate.   |
| Unexpected response from the touchpanel.                           | Touchpanel is incorrectly calibrated.                                   | Enter "SETUP MODE" and recalibrate.   |
| Communications via the LAN port not functioning.                   | Improper Ethernet connection (IEC).                                     | Verify proper connection at touchpanel LAN port.                                    |
|  | Another device set to the same IP address.                              | Obtain new touchpanel static IP address.  |

## Check Network Wiring

### *Use the Right Wire*

In order to ensure optimum performance over the full range of your installation topology, Crestron Certified Wire and only Crestron Certified Wire may be used. Failure to do so may incur additional charges if support is required to identify performance deficiencies because of using improper wire.

### *Calculate Power*

**CAUTION:** Use only Crestron power supplies for Crestron equipment. Failure to do so could cause equipment damage or void the Crestron warranty.

**CAUTION:** Provide sufficient power to the system. Insufficient power can lead to unpredictable results or damage to the equipment. Please use the Crestron Power Calculator to help calculate how much power is needed for the system (<http://www.crestron.com/calculators>).

When calculating the length of wire for a particular Cresnet run, the wire gauge and the Cresnet power usage of each network unit to be connected must be taken into consideration. Use Crestron Certified Wire only. If Cresnet units are to be daisy-chained on the run, the Cresnet power usage of each network unit to be daisy-chained must be added together to determine the Cresnet power usage of the entire chain. If the unit is home-run from a Crestron system power supply network port, the Cresnet power usage of that unit is the Cresnet power usage of the entire run. The

wire gauge and the Cresnet power usage of the run should be used in the following equation to calculate the cable length value on the equation's left side.

#### Cable Length Equation

$$L < \frac{40,000}{R \times P}$$

|   |
|---|
| <p>Where: L = Length of run (or chain) in feet<br/> R = 6 Ohms (Crestron Certified Wire: 18 AWG (0.75 MM<sup>2</sup>))<br/> or 1.6 Ohms (Cresnet HP: 12 AWG (4 MM<sup>2</sup>))<br/> P = Cresnet power usage of entire run (or chain)</p> |
|---|

Make sure the cable length value is less than the value calculated on the right side of the equation. For example, a Cresnet run using 18 AWG Crestron Certified Wire and drawing 20 watts should not have a length of run more than 333 feet. If Cresnet HP is used for the same run, its length could extend to 1250 feet.

---

**NOTE:** All Crestron certified Cresnet wiring must consist of two twisted pairs. One twisted pair is the +24V conductor and the GND conductor and the other twisted pair is the Y conductor and the Z conductor.

---

#### Strip and Tin Wire

When daisy-chaining Cresnet units, strip the ends of the wires carefully to avoid nicking the conductors. Twist together the ends of the wires that share a pin on the network connector and tin the twisted connection. Apply solder only to the ends of the twisted wires. Avoid tinning too far up the wires or the end becomes brittle. Insert the tinned connection into the Cresnet connector and tighten the retaining screw. Repeat the procedure for the other three conductors.

#### Add Hubs

For larger networks (i.e., greater than 28 network devices), it may become necessary to add a Cresnet Hub/Repeater (CNXHUB) to maintain signal quality throughout the network. Also, for networks with lengthy cable runs it may be necessary to add a Hub/Repeater after only 20 devices.

## Reference Documents

The latest version of all documents mentioned within the guide can be obtained from the Crestron website (<http://www.crestron.com/manuals>). This link will provide a list of product manuals arranged in alphabetical order by model number.

#### List of Related Reference Documents

| DOCUMENT TITLE                           |
|--|
| 2-Series Control Systems Reference Guide |
| CAT5 Wiring Reference Guide              |
| Crestron e-Control Reference Guide       |
| MediaManager Applications Guide          |
| QM-TX QuickMedia Transmitter             |
| TPMC-CH-IMC Interface Module             |

## Further Inquiries

If you cannot locate specific information or have questions after reviewing this guide, please take advantage of Crestron's award winning customer service team by calling the Crestron corporate headquarters at 1-888-CRESTRON [1-888-273-7876]. For assistance in your local time zone, refer to the Crestron website (<http://www.crestron.com/>) for a listing of Crestron worldwide offices.



You can also log onto the online help section of the Crestron website to ask questions about Crestron products. First-time users will need to establish a user account to fully benefit from all available features.

## **Future Updates**

As Crestron improves functions, adds new features and extends the capabilities of the TPS-12B/W, TPS-15B/W & TPS-17B/W, additional information may be made available as manual updates. These updates are solely electronic and serve as intermediary supplements prior to the release of a complete technical documentation revision.

Check the Crestron website periodically for manual update availability and its relevance. Updates are identified as an “Addendum” in the Download column.

## Software License Agreement

This License Agreement (“Agreement”) is a legal contract between you (either an individual or a single business entity) and Crestron Electronics, Inc. (“Crestron”) for software referenced in this guide, which includes computer software and as applicable, associated media, printed materials and “online” or electronic documentation (the “Software”).

BY INSTALLING, COPYING OR OTHERWISE USING THE SOFTWARE, YOU REPRESENT THAT YOU ARE AN AUTHORIZED DEALER OF CRESTRON PRODUCTS OR A CRESTRON AUTHORIZED INDEPENDENT PROGRAMMER AND YOU AGREE TO BE BOUND BY THE TERMS OF THIS AGREEMENT. IF YOU DO NOT AGREE TO THE TERMS OF THIS AGREEMENT, DO NOT INSTALL OR USE THE SOFTWARE.

IF YOU HAVE PAID A FEE FOR THIS LICENSE AND DO NOT ACCEPT THE TERMS OF THIS AGREEMENT, CRESTRON WILL REFUND THE FEE TO YOU PROVIDED YOU (1) CLICK THE DO NOT ACCEPT BUTTON, (2) DO NOT INSTALL THE SOFTWARE AND (3) RETURN ALL SOFTWARE, MEDIA AND OTHER DOCUMENTATION AND MATERIALS PROVIDED WITH THE SOFTWARE TO CRESTRON AT: CRESTRON ELECTRONICS, INC., 15 VOLVO DRIVE, ROCKLEIGH, NEW JERSEY 07647, WITHIN 30 DAYS OF PAYMENT.

### LICENSE TERMS

Crestron hereby grants You and You accept a nonexclusive, nontransferable license to use the Software (a) in machine readable object code together with the related explanatory written materials provided by Crestron (b) on a central processing unit (“CPU”) owned or leased or otherwise controlled exclusively by You and (c) only as authorized in this Agreement and the related explanatory files and written materials provided by Crestron.

If this software requires payment for a license, you may make one backup copy of the Software, provided Your backup copy is not installed or used on any CPU. You may not transfer the rights of this Agreement to a backup copy unless the installed copy of the Software is destroyed or otherwise inoperable and You transfer all rights in the Software.

You may not transfer the license granted pursuant to this Agreement or assign this Agreement without the express written consent of Crestron.

If this software requires payment for a license, the total number of CPU’s on which all versions of the Software are installed may not exceed one per license fee (1) and no concurrent, server or network use of the Software (including any permitted back-up copies) is permitted, including but not limited to using the Software (a) either directly or through commands, data or instructions from or to another computer (b) for local, campus or wide area network, internet or web hosting services or (c) pursuant to any rental, sharing or “service bureau” arrangement.

The Software is designed as a software development and customization tool. As such Crestron cannot and does not guarantee any results of use of the Software or that the Software will operate error free and You acknowledge that any development that You perform using the Software or Host Application is done entirely at Your own risk.

The Software is licensed and not sold. Crestron retains ownership of the Software and all copies of the Software and reserves all rights not expressly granted in writing.

### OTHER LIMITATIONS

You must be an Authorized Dealer of Crestron products or a Crestron Authorized Independent Programmer to install or use the Software. If Your status as a Crestron Authorized Dealer or Crestron Authorized Independent Programmer is terminated, Your license is also terminated.

You may not rent, lease, lend, sublicense, distribute or otherwise transfer or assign any interest in or to the Software.

You may not reverse engineer, decompile or disassemble the Software.

You agree that the Software will not be shipped, transferred or exported into any country or used in any manner prohibited by the United States Export Administration Act or any other export laws, restrictions or regulations (“Export Laws”). By downloading or installing the Software You (a) are certifying that You are not a national of Cuba, Iran, Iraq, Libya, North Korea, Sudan, Syria or any country to which the United States embargoes goods (b) are certifying that You are not otherwise prohibited from receiving the Software and (c) You agree to comply with the Export Laws.

If any part of this Agreement is found void and unenforceable, it will not affect the validity of the balance of the Agreement, which shall remain valid and enforceable according to its terms. This Agreement may only be modified by a writing signed by an authorized officer of Crestron. Updates may be licensed to You by Crestron with additional or different terms. This is the entire agreement between Crestron and You relating to the Software and it supersedes any prior representations, discussions, undertakings, communications or advertising relating to the Software. The failure of either party to enforce any right or take any action in the event of a breach hereunder shall constitute a waiver unless expressly acknowledged and set forth in writing by the party alleged to have provided such waiver.

If You are a business or organization, You agree that upon request from Crestron or its authorized agent, You will within thirty (30) days fully document and certify that use of any and all Software at the time of the request is in conformity with Your valid licenses from Crestron or its authorized agent.

Without prejudice to any other rights, Crestron may terminate this Agreement immediately upon notice if you fail to comply with the terms and conditions of this Agreement. In such event, you must destroy all copies of the Software and all of its component parts.

#### PROPRIETARY RIGHTS

**Copyright.** All title and copyrights in and to the Software (including, without limitation, any images, photographs, animations, video, audio, music, text and “applets” incorporated into the Software), the accompanying media and printed materials and any copies of the Software are owned by Crestron or its suppliers. The Software is protected by copyright laws and international treaty provisions. Therefore, you must treat the Software like any other copyrighted material, subject to the provisions of this Agreement.

**Submissions.** Should you decide to transmit to Crestron’s website by any means or by any media any materials or other information (including, without limitation, ideas, concepts or techniques for new or improved services and products), whether as information, feedback, data, questions, comments, suggestions or the like, you agree such submissions are unrestricted and shall be deemed non-confidential and you automatically grant Crestron and its assigns a non-exclusive, royalty-free, worldwide, perpetual, irrevocable license, with the right to sublicense, to use, copy, transmit, distribute, create derivative works of, display and perform the same.

**Trademarks.** CRESTRON and the Swirl Logo are registered trademarks of Crestron Electronics, Inc. You shall not remove or conceal any trademark or proprietary notice of Crestron from the Software including any back-up copy.

#### GOVERNING LAW

This Agreement shall be governed by the laws of the State of New Jersey, without regard to conflicts of laws principles. Any disputes between the parties to the Agreement shall be brought in the state courts in Bergen County, New Jersey or the federal courts located in the District of New Jersey. The United Nations Convention on Contracts for the International Sale of Goods shall not apply to this Agreement.

#### CRESTRON LIMITED WARRANTY

CRESTRON warrants that: (a) the Software will perform substantially in accordance with the published specifications for a period of ninety (90) days from the date of receipt and (b) that any hardware accompanying the Software will be subject to its own limited warranty as stated in its accompanying written material. Crestron shall, at its option, repair or replace or refund the license fee for any Software found defective by Crestron if notified by you within the warranty period. The foregoing remedy shall be your exclusive remedy for any claim or loss arising from the Software.

CRESTRON shall not be liable to honor warranty terms if the product has been used in any application other than that for which it was intended or if it as been subjected to misuse, accidental damage, modification or improper installation procedures. Furthermore, this warranty does not cover any product that has had the serial number or license code altered, defaced, improperly obtained or removed.

Notwithstanding any agreement to maintain or correct errors or defects, Crestron shall have no obligation to service or correct any error or defect that is not reproducible by Crestron or is deemed in Crestron’s reasonable discretion to have resulted from (1) accident; unusual stress; neglect; misuse; failure of electric power, operation of the Software with other media not meeting or not maintained in accordance with the manufacturer’s specifications or causes other than ordinary use; (2) improper installation by anyone other than Crestron or its authorized agents of the Software that deviates from any operating procedures established by Crestron in the material and files provided to You by Crestron or its authorized agent; (3) use of the Software on unauthorized hardware or (4) modification of, alteration of or additions to the Software undertaken by persons other than Crestron or Crestron’s authorized agents.

ANY LIABILITY OF CRESTRON FOR A DEFECTIVE COPY OF THE SOFTWARE WILL BE LIMITED EXCLUSIVELY TO REPAIR OR REPLACEMENT OF YOUR COPY OF THE SOFTWARE WITH ANOTHER COPY OR REFUND OF THE INITIAL LICENSE FEE CRESTRON RECEIVED FROM YOU FOR THE DEFECTIVE COPY OF THE PRODUCT. THIS WARRANTY SHALL BE THE SOLE AND EXCLUSIVE REMEDY TO YOU. IN NO EVENT SHALL CRESTRON BE LIABLE FOR INCIDENTAL, CONSEQUENTIAL, SPECIAL OR PUNITIVE DAMAGES OF ANY KIND (PROPERTY OR ECONOMIC DAMAGES INCLUSIVE), EVEN IF A CRESTRON REPRESENTATIVE HAS BEEN ADVISED OF THE POSSIBILITY OF SUCH DAMAGES OR OF ANY CLAIM BY ANY THIRD PARTY. CRESTRON MAKES NO WARRANTIES, EXPRESS OR IMPLIED, AS TO TITLE OR INFRINGEMENT OF THIRD-PARTY RIGHTS, MERCHANTABILITY OR FITNESS FOR ANY PARTICULAR PURPOSE, OR ANY OTHER WARRANTIES, NOR AUTHORIZES ANY OTHER PARTY TO OFFER ANY WARRANTIES, INCLUDING WARRANTIES OF MERCHANTABILITY FOR THIS PRODUCT. THIS WARRANTY STATEMENT SUPERSEDES ALL PREVIOUS WARRANTIES.

## Return and Warranty Policies

### Merchandise Returns / Repair Service

1. No merchandise may be returned for credit, exchange or service without prior authorization from CRESTRON. To obtain warranty service for CRESTRON products, contact an authorized CRESTRON dealer. Only authorized CRESTRON dealers may contact the factory and request an RMA (Return Merchandise Authorization) number. Enclose a note specifying the nature of the problem, name and phone number of contact person, RMA number and return address.
2. Products may be returned for credit, exchange or service with a CRESTRON Return Merchandise Authorization (RMA) number. Authorized returns must be shipped freight prepaid to CRESTRON, 6 Volvo Drive, Rockleigh, N.J. or its authorized subsidiaries, with RMA number clearly marked on the outside of all cartons. Shipments arriving freight collect or without an RMA number shall be subject to refusal. CRESTRON reserves the right in its sole and absolute discretion to charge a 15% restocking fee plus shipping costs on any products returned with an RMA.
3. Return freight charges following repair of items under warranty shall be paid by CRESTRON, shipping by standard ground carrier. In the event repairs are found to be non-warranty, return freight costs shall be paid by the purchaser.

### CRESTRON Limited Warranty

CRESTRON ELECTRONICS, Inc. warrants its products to be free from manufacturing defects in materials and workmanship under normal use for a period of three (3) years from the date of purchase from CRESTRON, with the following exceptions: disk drives and any other moving or rotating mechanical parts, pan/tilt heads and power supplies are covered for a period of one (1) year; touchscreen display and overlay components are covered for 90 days; batteries and incandescent lamps are not covered.

This warranty extends to products purchased directly from CRESTRON or an authorized CRESTRON dealer. Purchasers should inquire of the dealer regarding the nature and extent of the dealer's warranty, if any.

CRESTRON shall not be liable to honor the terms of this warranty if the product has been used in any application other than that for which it was intended or if it has been subjected to misuse, accidental damage, modification or improper installation procedures. Furthermore, this warranty does not cover any product that has had the serial number altered, defaced or removed.

This warranty shall be the sole and exclusive remedy to the original purchaser. In no event shall CRESTRON be liable for incidental or consequential damages of any kind (property or economic damages inclusive) arising from the sale or use of this equipment. CRESTRON is not liable for any claim made by a third party or made by the purchaser for a third party.

CRESTRON shall, at its option, repair or replace any product found defective, without charge for parts or labor. Repaired or replaced equipment and parts supplied under this warranty shall be covered only by the unexpired portion of the warranty.

Except as expressly set forth in this warranty, CRESTRON makes no other warranties, expressed or implied, nor authorizes any other party to offer any warranty, including any implied warranties of merchantability or fitness for a particular purpose. Any implied warranties that may be imposed by law are limited to the terms of this limited warranty. This warranty statement supersedes all previous warranties.

#### Trademark Information

*All brand names, product names and trademarks are the sole property of their respective owners. Windows is a registered trademark of Microsoft Corporation. Windows95/98/Me/XP and WindowsNT/2000 are trademarks of Microsoft Corporation.*

This page is intentionally left blank.



**Crestron Electronics, Inc.**  
15 Volvo Drive Rockleigh, NJ 07647  
Tel: 888.CRESTRON  
Fax: 201.767.7576  
[www.crestron.com](http://www.crestron.com)

**Operations Guide – DOC. 6464A**  
**(2014556)**  
**11.06**  
Specifications subject to  
change without notice.